



WWW.HSPUTELIDS.COM

1300 441 498

Part No: LD18 Fitting

Time: 1.5 hours



LDV T60

HSP TAIL LOCK

---

FITTING INSTRUCTIONS

## —GENERAL NOTES

- Read through the fitting instructions prior to installation of accessory.
- Ensure all recyclable components and packaging are discarded and recycled following local recycling regulations.
- Safely store and protect any removed vehicle components.

## —SAFETY NOTES

- Check that all work practices comply with safety standards.
- Please wear appropriate clothing and use safety equipment.

## —FITTING TIME



1.5 hours

## —PARTS SUPPLIED

Part Description	Part Number	Quality/ Length	CHECK LIST
<b>TAIL LOCK ASSEMBLY</b>			
Main Bracket	LD18-A	1	
Tube	LD18-B	1	
Actuator	ACT-01	1	
Wiring	CL-Long-Loom	1	
Patch	LD-Patch	1	
<b>FASTENERS</b>			
Actuator Screws	36	2	
M6 x 25mm	38	1	
M6 Spring washer	13	1	
Spacer	39	1	
<b>OTHER</b>			
Cable Ties		5	
Fitting Instruction		1	

— STEP 1 —

Attach plastic rod in the orintaion indicated.

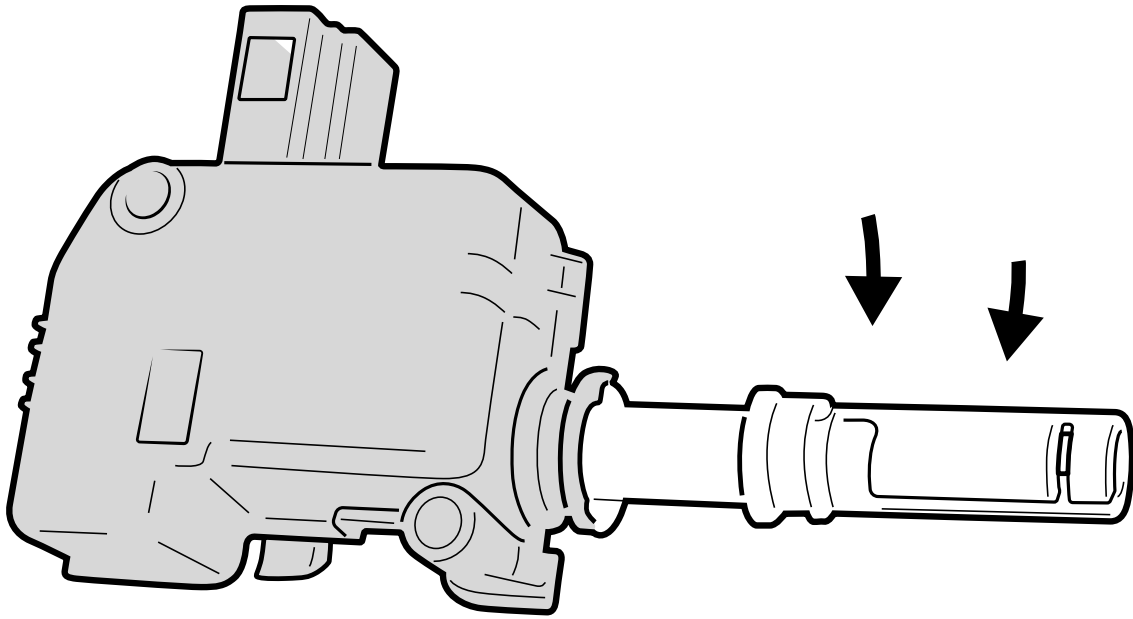

— STEP 2 —

Using a heat gun, warm up the plastic striker of the actuator (A), then insert into the tube (B) of the actuator as shown, please make sure there is no gap between the tube and end of striker.

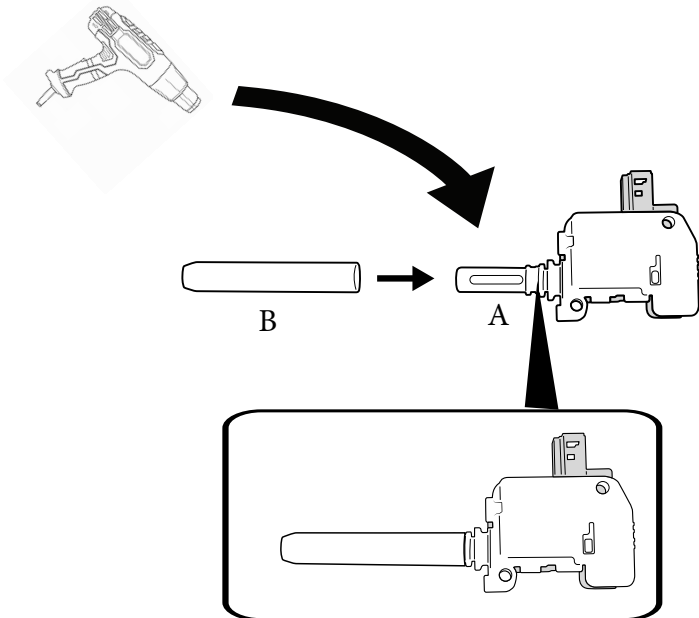

—STEP 3—

Load actuator on the Tail Lock bracket as shown.

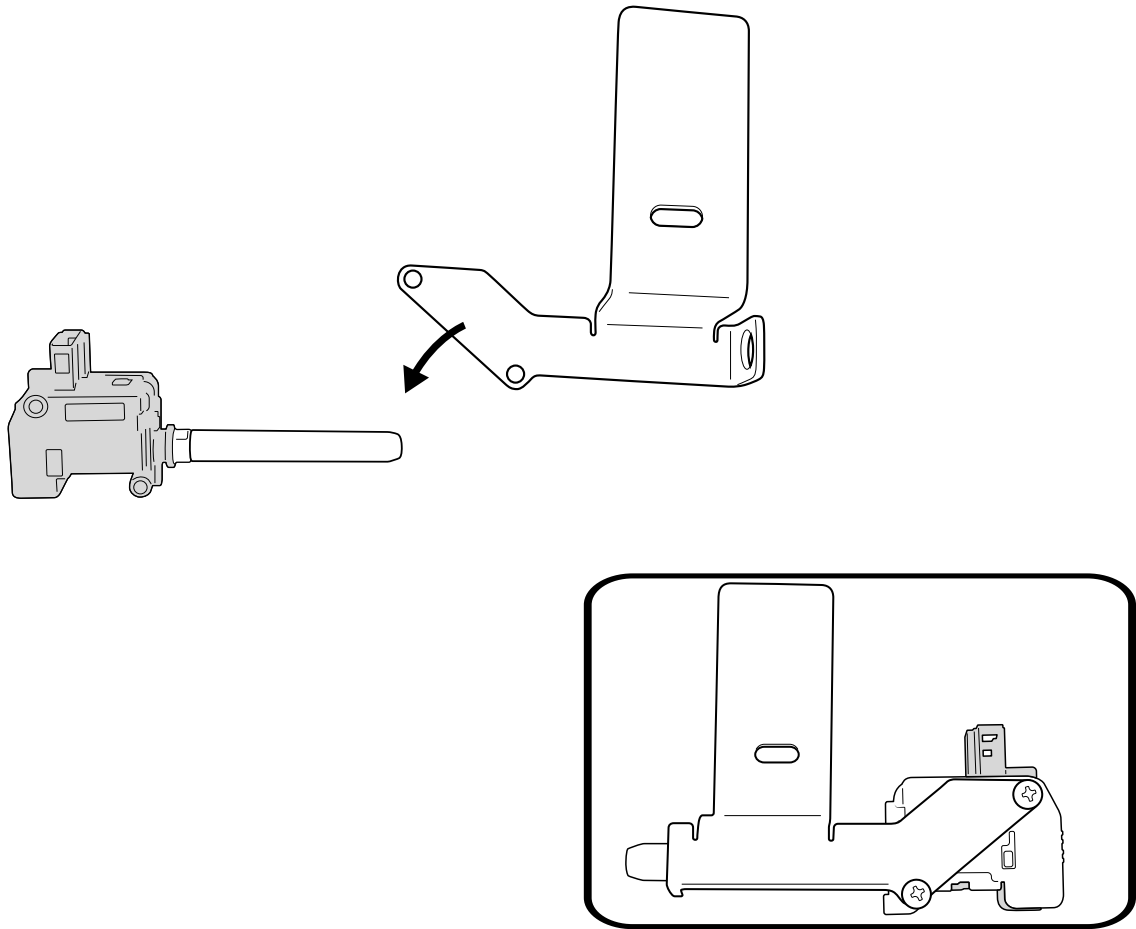

Turn around and fasten with the actuator screws provided.

—STEP 4—

Remove tail gate cover.

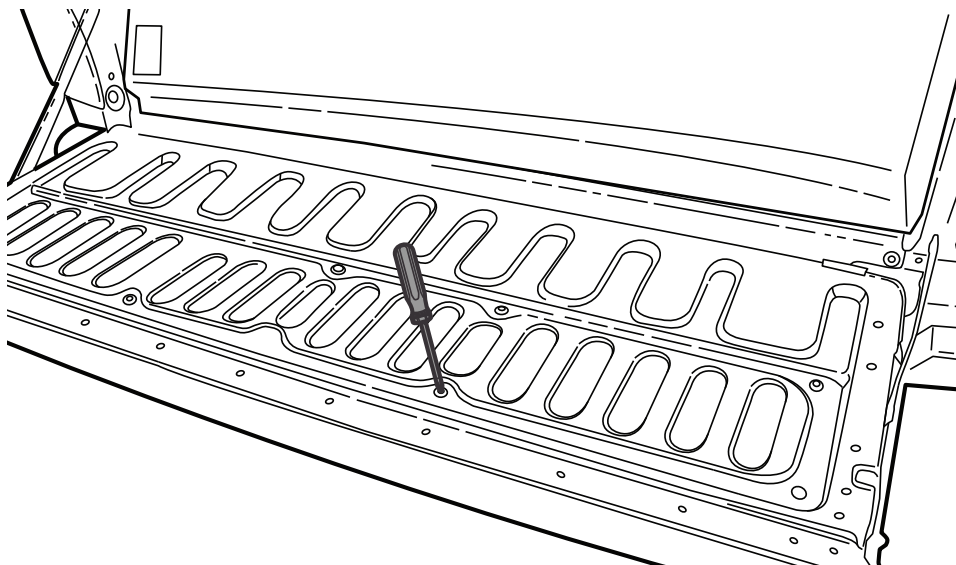

— STEP 5 —

Remove indicated rod shown.

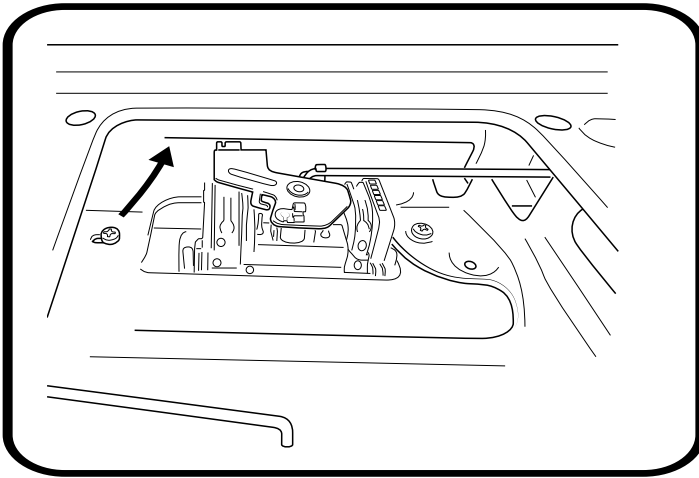
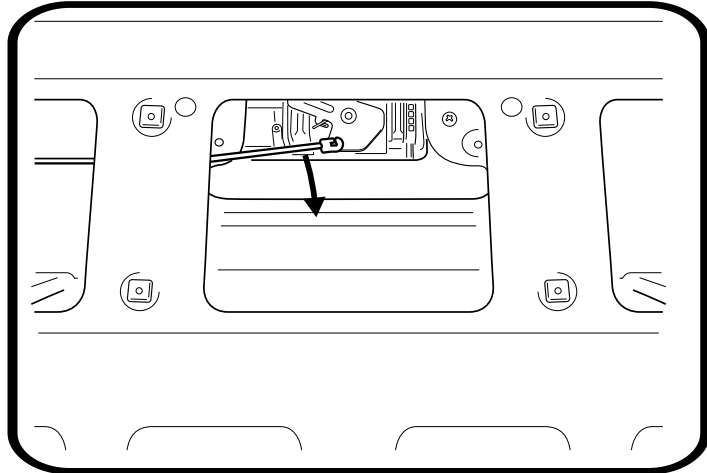

Remove indicated factory bolt holding the tailgate handle and discard .

— STEP 6 —

Place spacer as indicated.

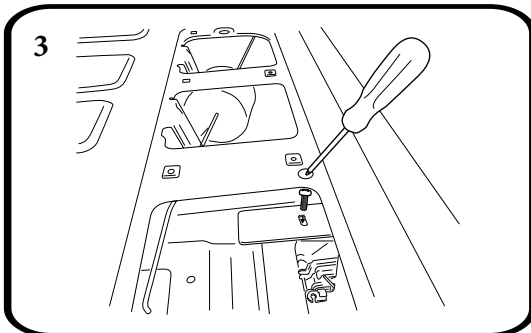
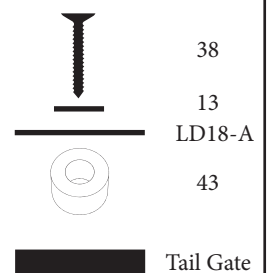
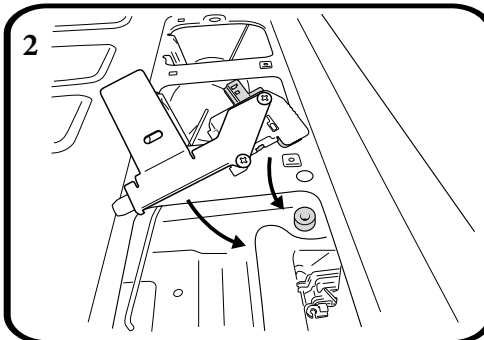
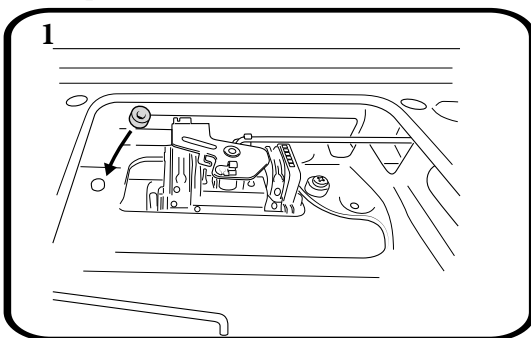

Place assembled bracket into the cavity lining up the slotted hole on the bracket to the spacer & thread of the handle , followed by spring washer then loosely screw in the m6 x 25mm bolt.

—STEP 7—

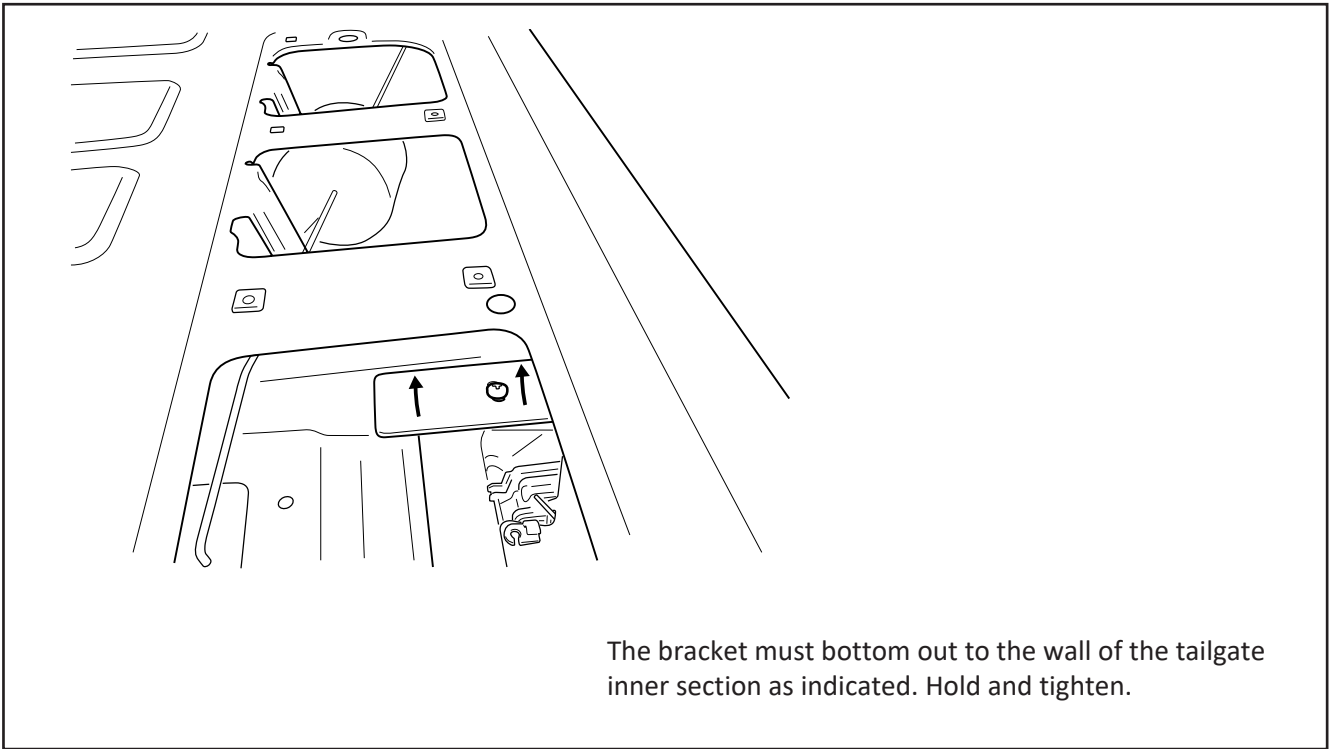

—STEP 8—

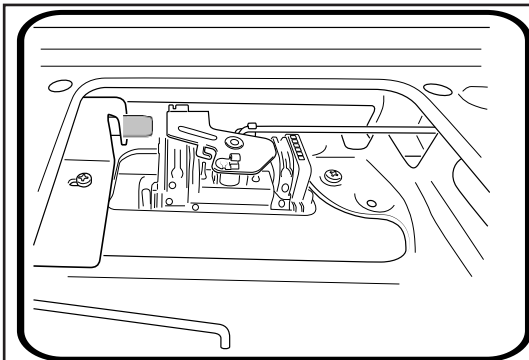

Lock cam in unlocked position.

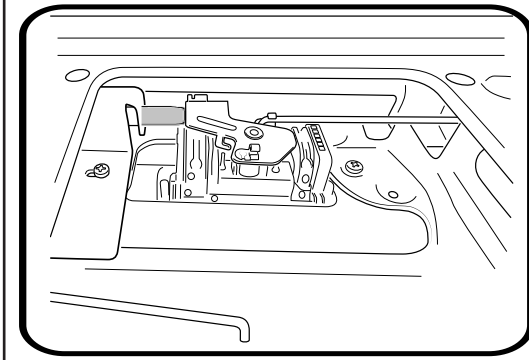

Lock cam in locked position.

## — STEP 9 —

Refit indicated rod shown.

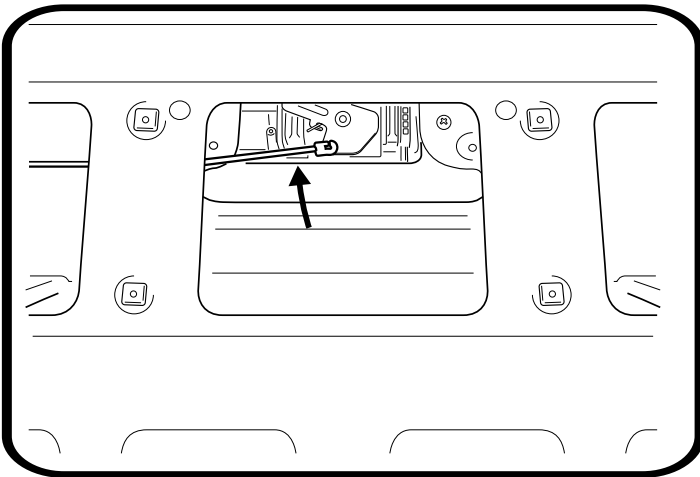

## — STEP 10 —

Connect the wiring to the actuator then route the actuator wiring harness (1) out of the tailgate and underneath the vehicle following the existing vehicle harness.

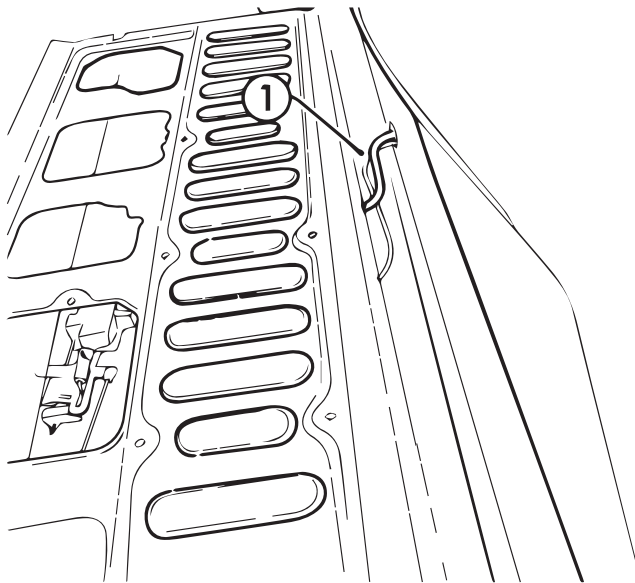

## — STEP 11 —

Run wiring (CL-LONG-LOOM) from tailgate to front driver doorr over chassis rail.

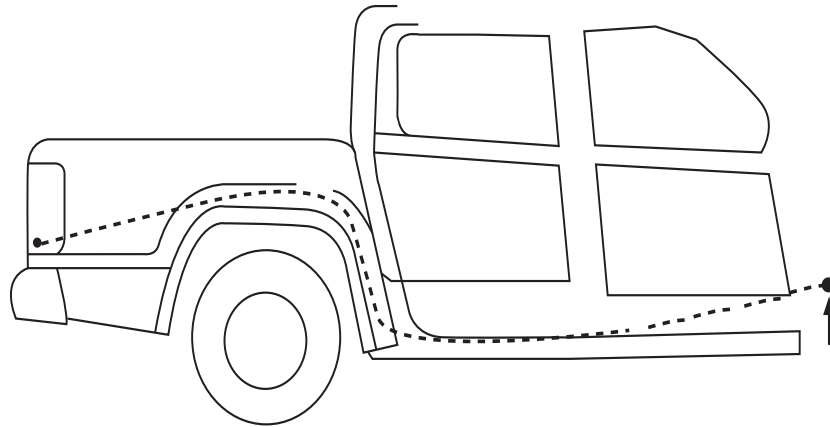

Make an incision and run wiring through floor grommet. Remembering to silicon when finished.

## — STEP 12 —

Carefully remove the drivers side scuff and kick panel.

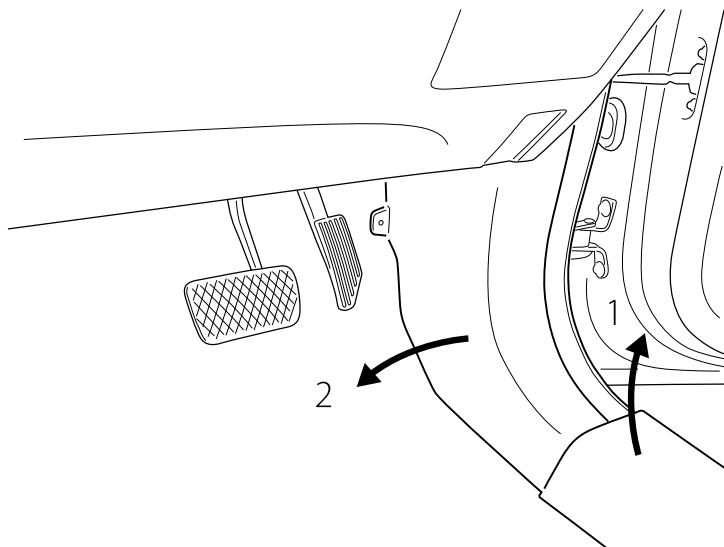



—STEP 13—

look up above the kick panel area

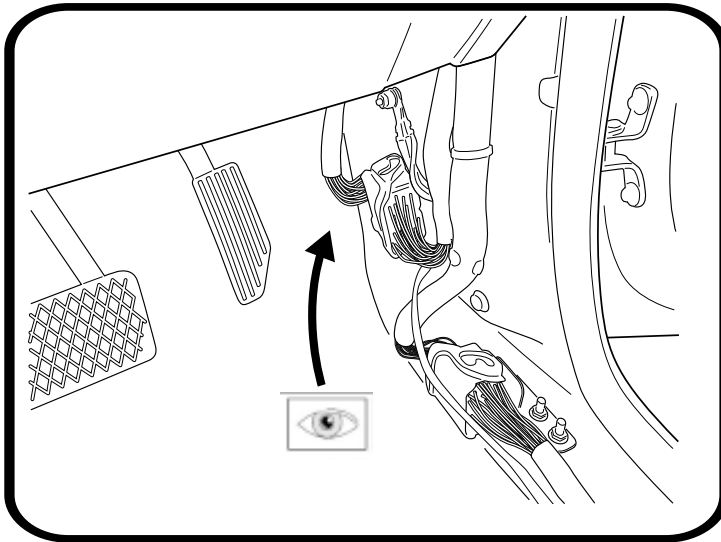

—STEP 14—

locate connector as indicated and unplug.

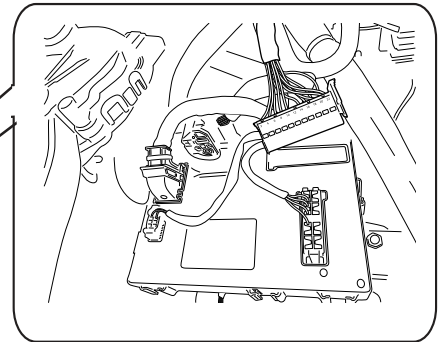
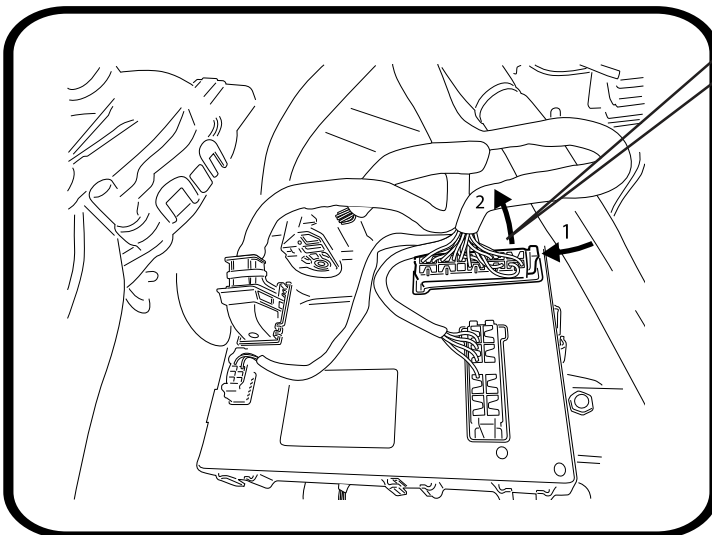

— STEP 15 —

Un-clip the plugs interface to gain access to the wire's.

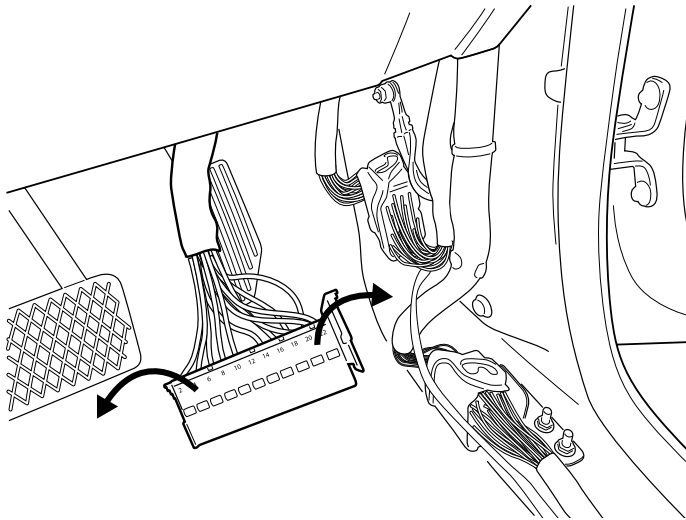

— STEP 16 —

Remove the yellow wire (18) and grey wire (20) from the plug.

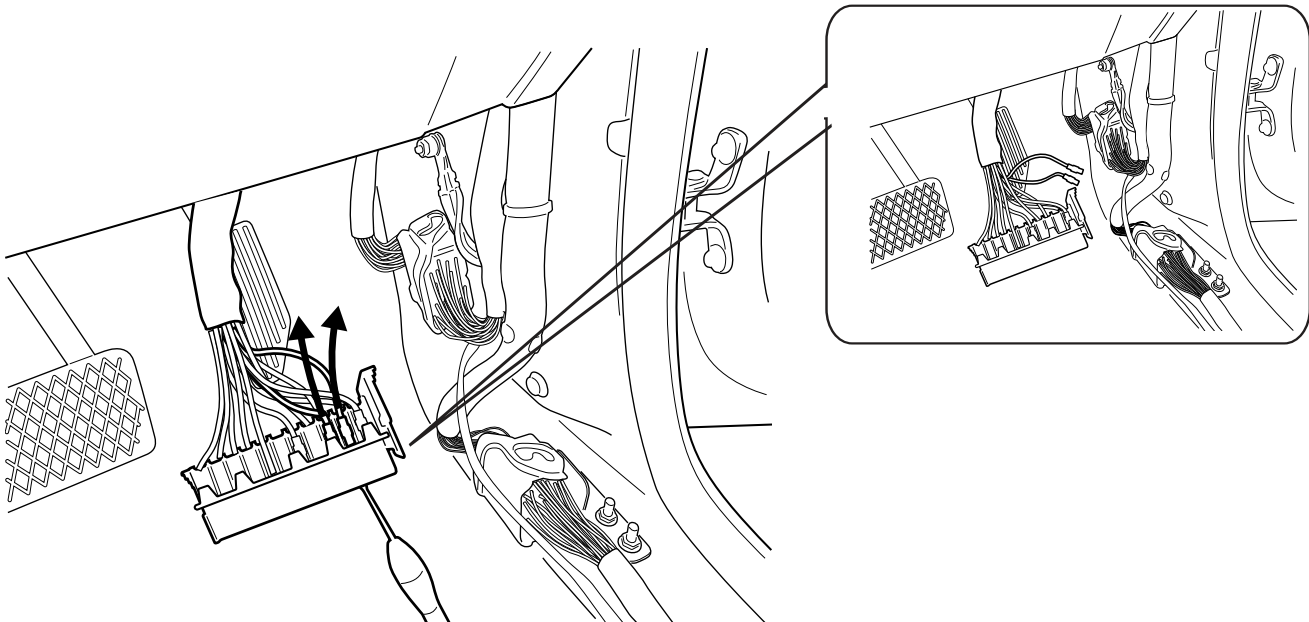

## — STEP 17 —

Using male connector (LD patch).

A = Grey wire

B = Yellow wire

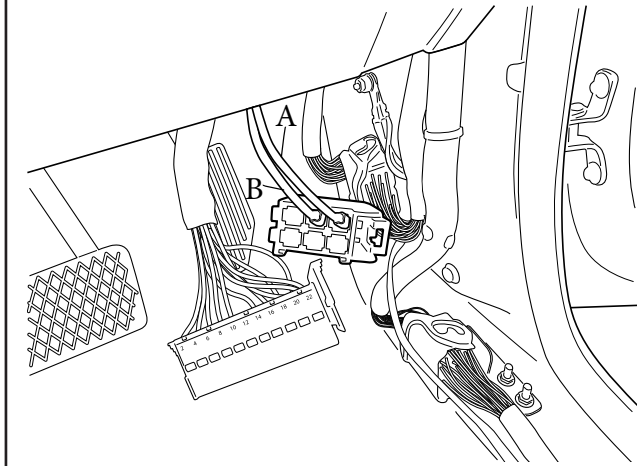

After terminal install, push lock in to plug

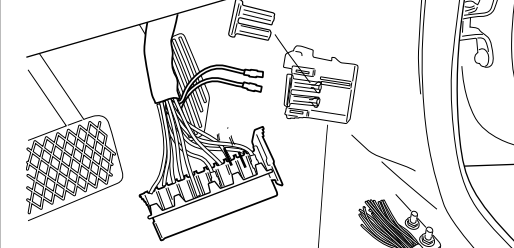

Male connector (LDpatch)

## — STEP 18 —

Using the LD- patch provided in the kit, plug the green wire to (20) & blue (18) on the factory plug.

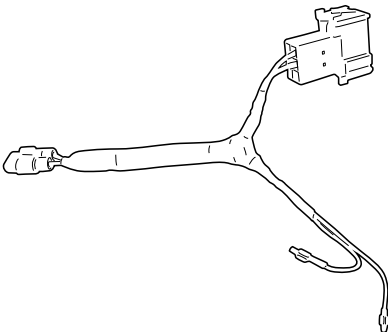

Making sure the wires are connected according to factory orientation

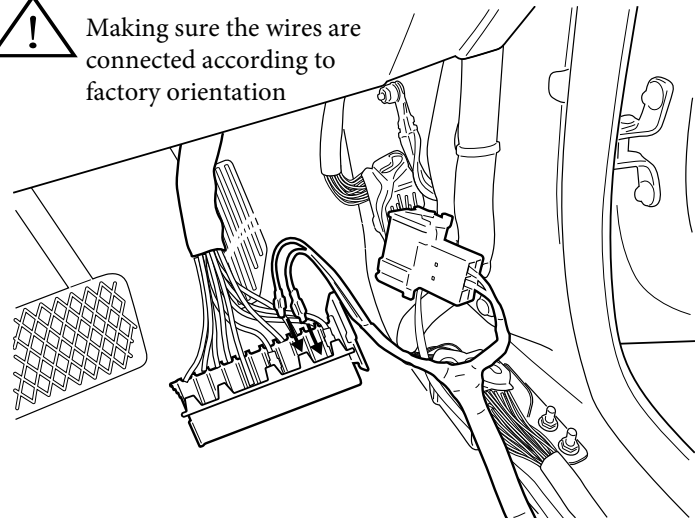

Clip the connector lock back so the wires are secured.

— STEP 19 —

Plug the male connector to the female connector of the LD patch.

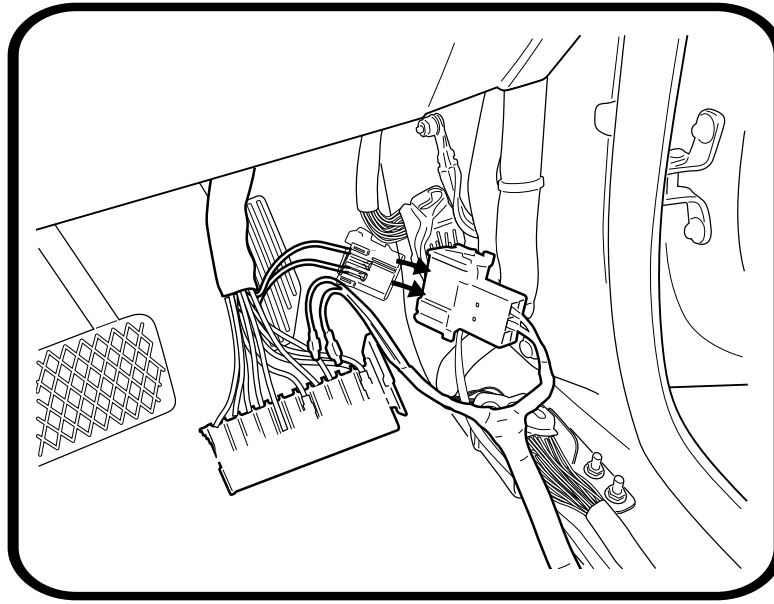

— STEP 20 —

Connect the male and female plugs from the LD patch & CL- long-Loom to each other.

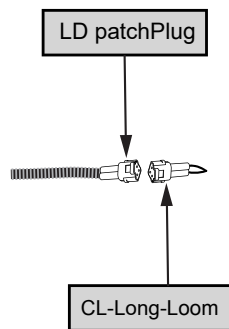

— STEP 21 —

Place and fasten tail gate cover.

