



WWW.HSPUTELIDS.COM

Part No: MBT4R

Fitting Time: 120 minutes

ROLL-R-COVER

MAZDA BT-50 Dual Cab MY21, 07/2020+

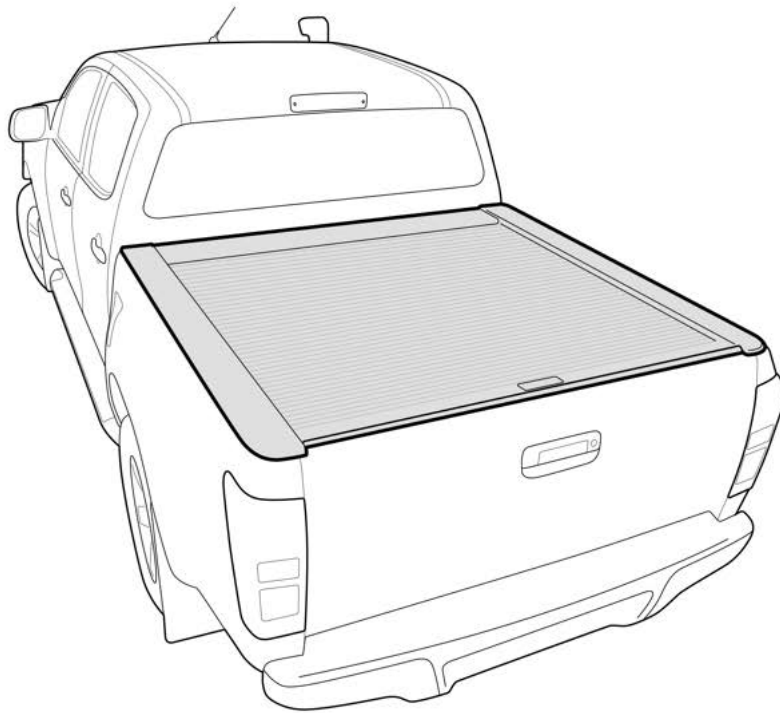

Roll-R-Cover

Fitting Instructions

– General Notes

- Read through the fitting instructions before installation of accessory.
- Always install the Roll R Cover Wiring Kit following the workshop manual and fitting instructions provided. Failure to do so may cause damage to the vehicle or the accessory.
- Ensure all recyclable components and packaging are discarded and recycled following local recycling regulations.
- It is always recommended that the Roll R Cover Wiring Kit is fitted by a qualified automotive technician.
- Safely store and protect any removed vehicle components.

– Safety Notes

- Check that all work practices comply with safety standards.
- Please wear appropriate clothing and use safety equipment.



– Fitting Time



180 minutes

– Parts Supplied

MBT4R	MAZDA BT50 DUAL CAB ROLL R COVER		
<u>PART DISCIPTION</u>	<u>PART NUMBER</u>	<u>QUANTITY/LENGTH</u>	<u>CHECK</u>
MBT4R FITTING INSTRUCTIONS	677	1	
MBT4R CANISTER AND CURTAIN	678	1	
MBT4R COMPLETE CANISTER COVER	679	1	
MBT4R RAIL RIGHTHAND	680	1	
MBT4R RAIL LEFTHAND	681	1	
REMOTE	215	2	
CABLE TIE	501	1	
CABLE TIE 4.8X300MM	217	10	
HOSE 600MM	11	4	
ROLL R LOOM	216	1	
LUBRICANT SPRAY	47	1	
OPERATION LEAFLET	66	1	
MAINTENANCE LEAFLET	67	1	
ADJUSTMENT PLATES	31	2	
PRIMER STICK	44	2	
BLACK PUTTY	3	8	

**The following steps are for vehicles with bed liners.
If there are no bed liners installed move to Step 4**

– Step 1

Trim front of bed liner by 180mm from the top of the ute bed as shown.

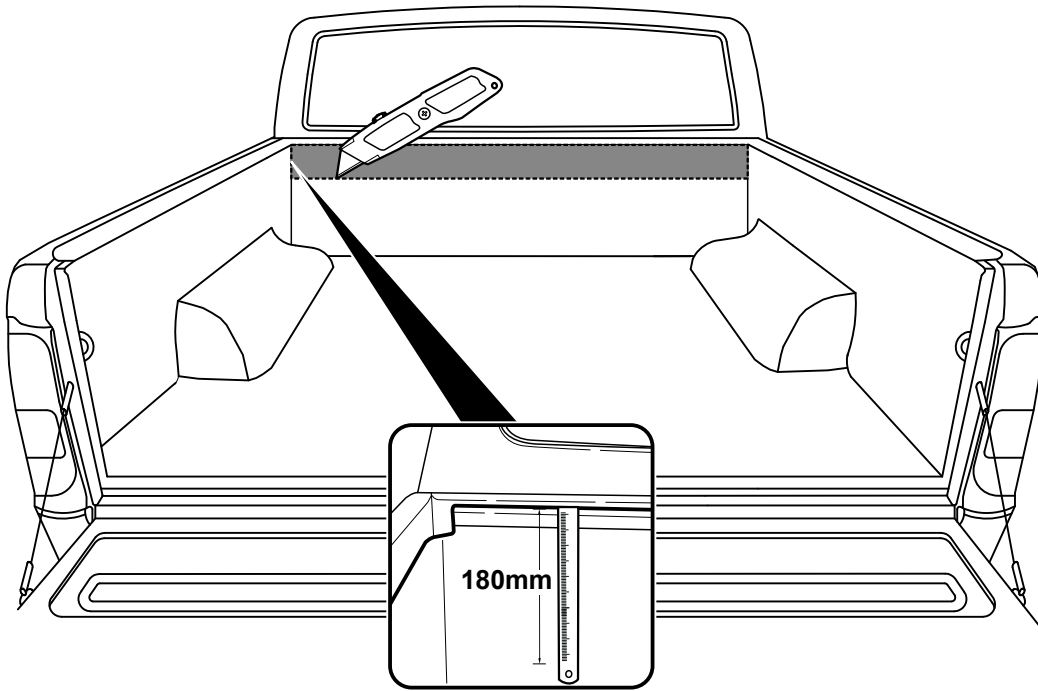

– Step 2

Cut a 20mm split for bed liner to flex.

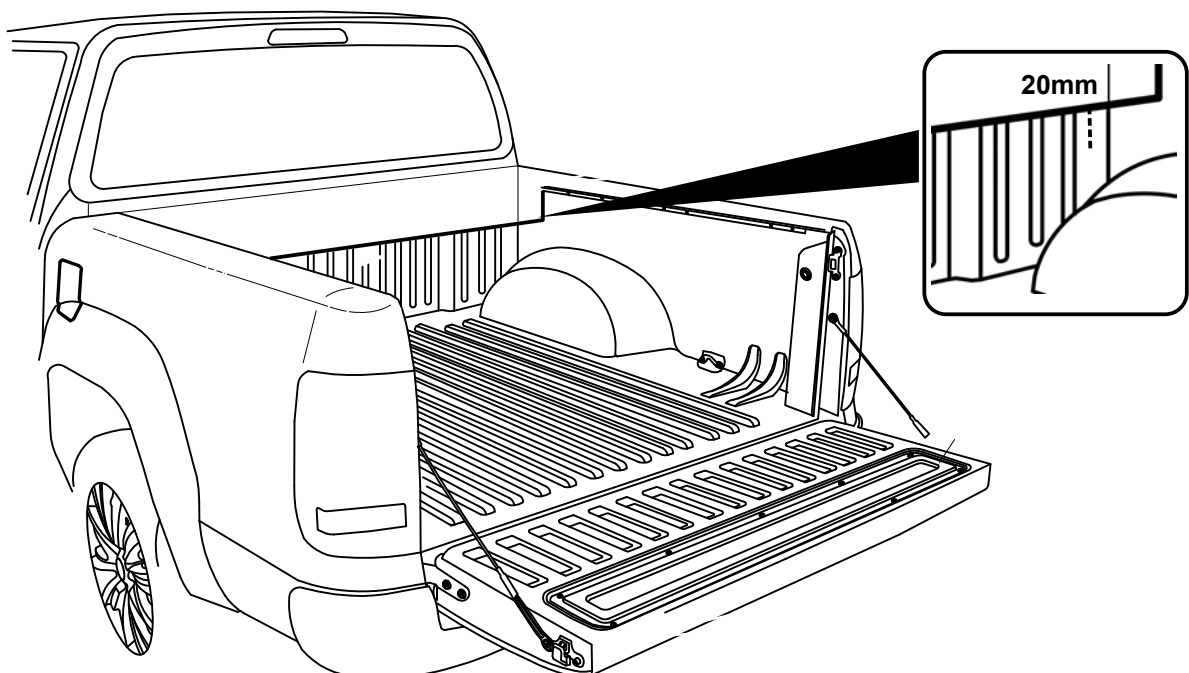

– Step 3

Measure 20mm down from top of tailgate and trim tailgate liner.

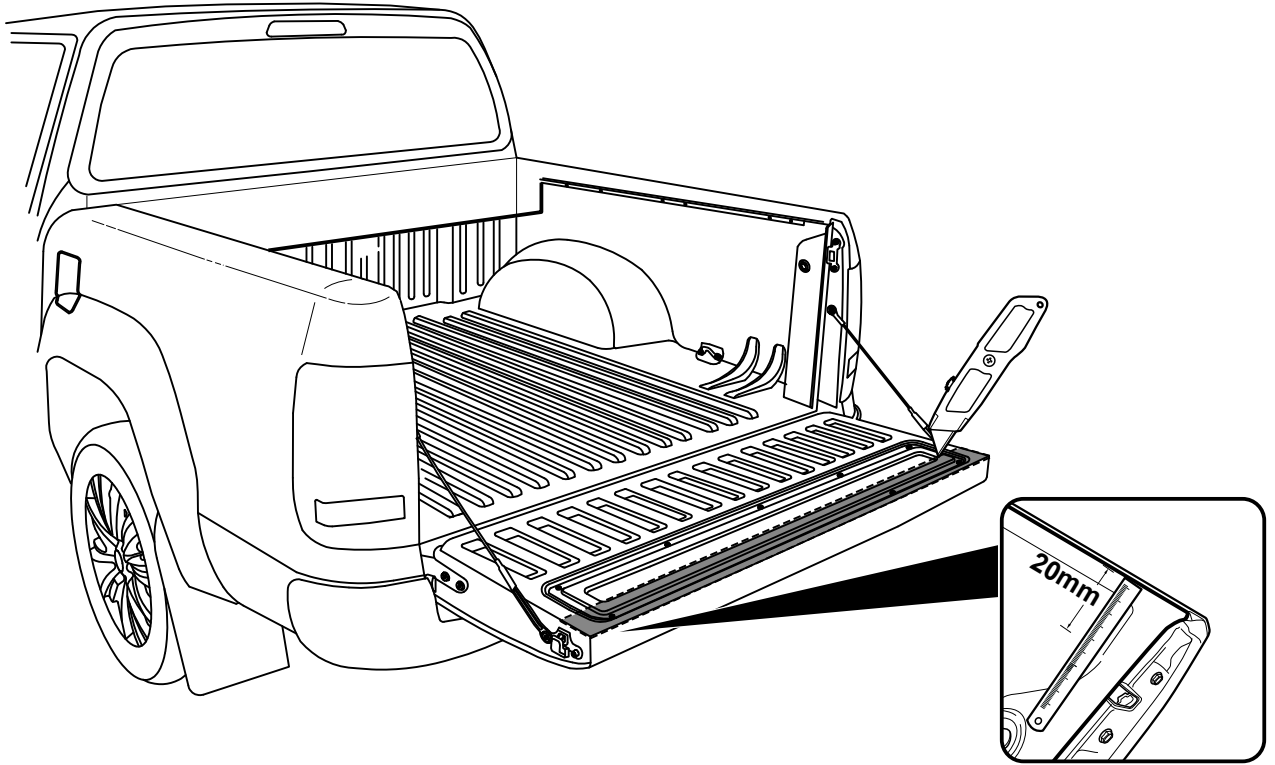

– Step 4

Roll-R-Cover preparation steps

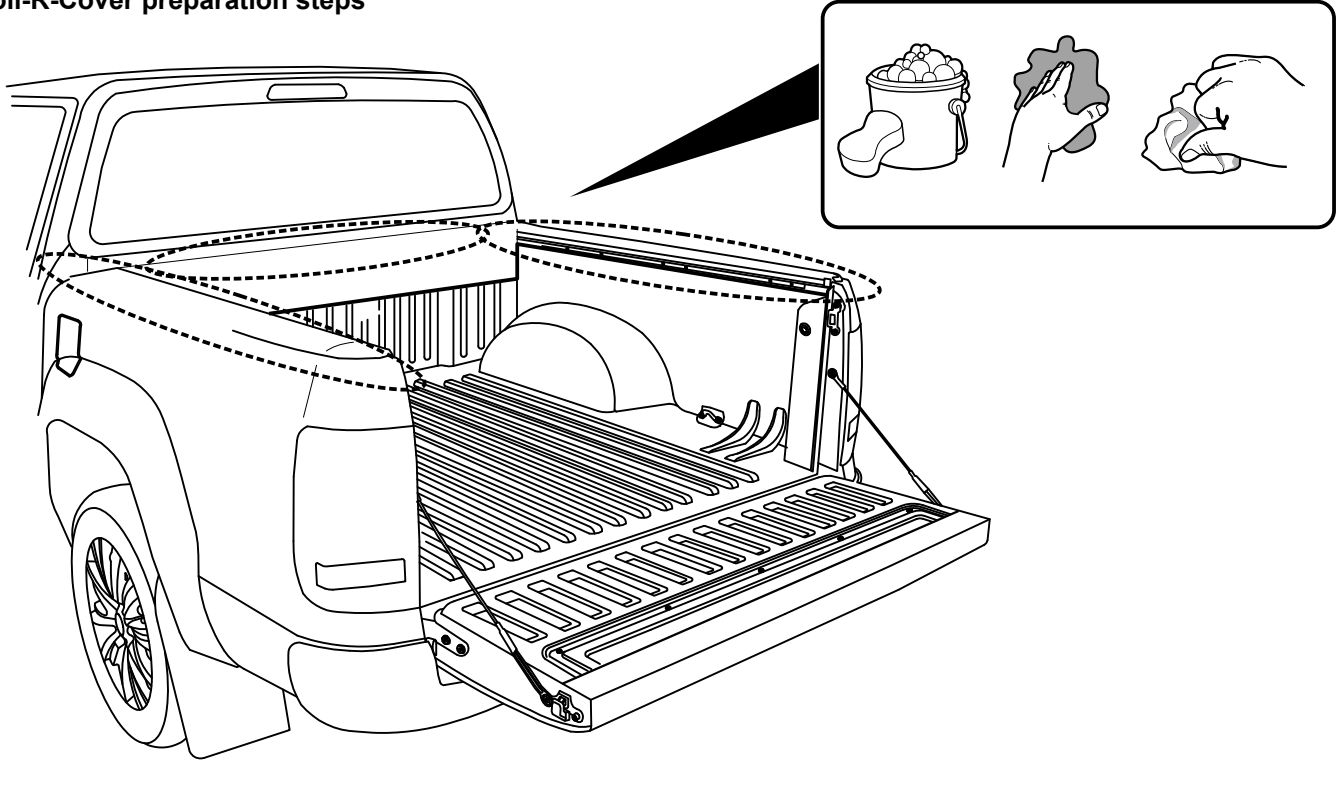

– Step 5

Carefully unpack the box.

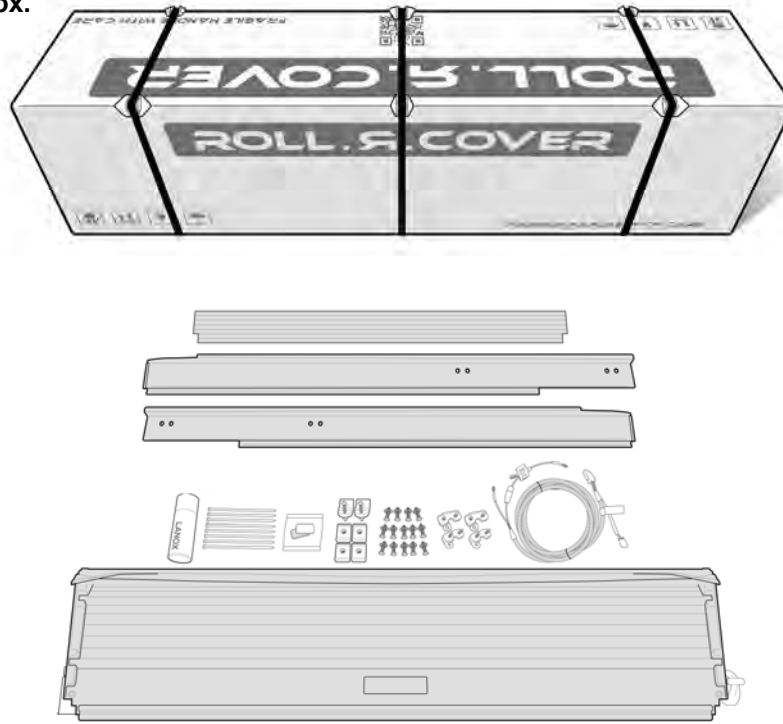

– Step 6

Wiring Harness steps

1 Feed through the cavity

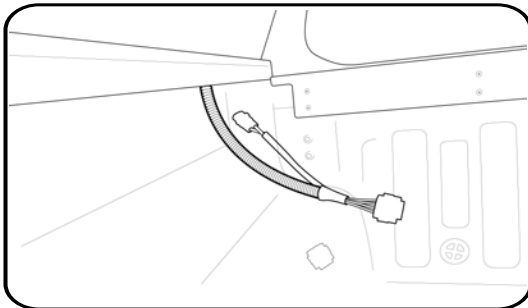

3

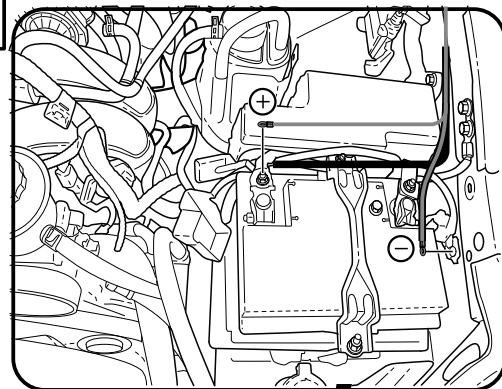

2

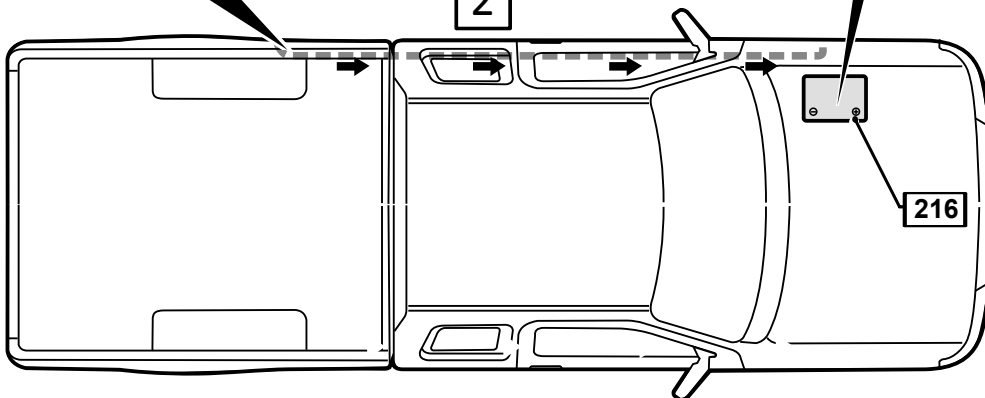

Run the wiring from the front corner cavity to the battery over the chassis rail. Making sure to keep away from hot obstructions and cable tie every 400mm.

– Step 7 –

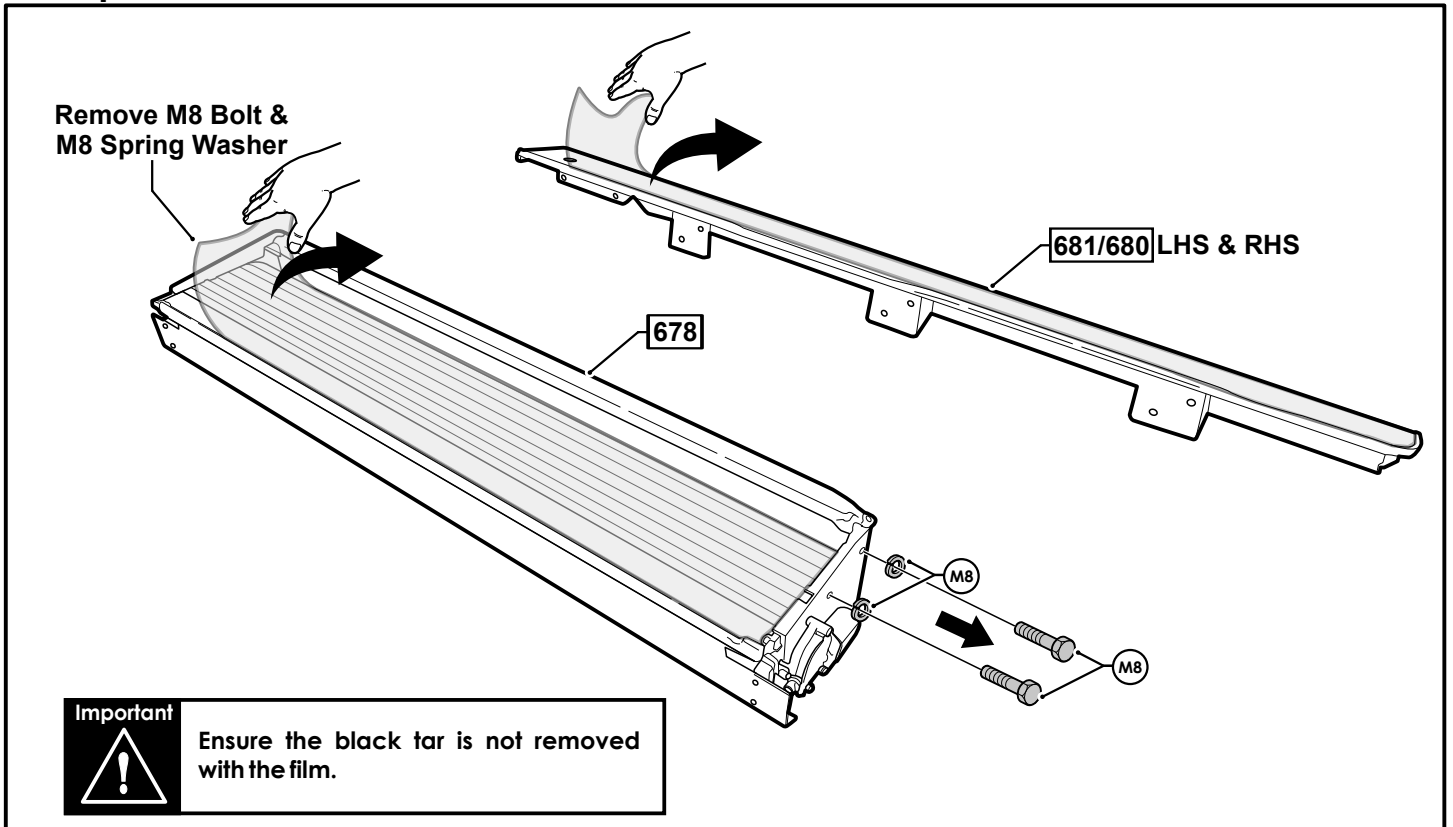

– Step 8 –

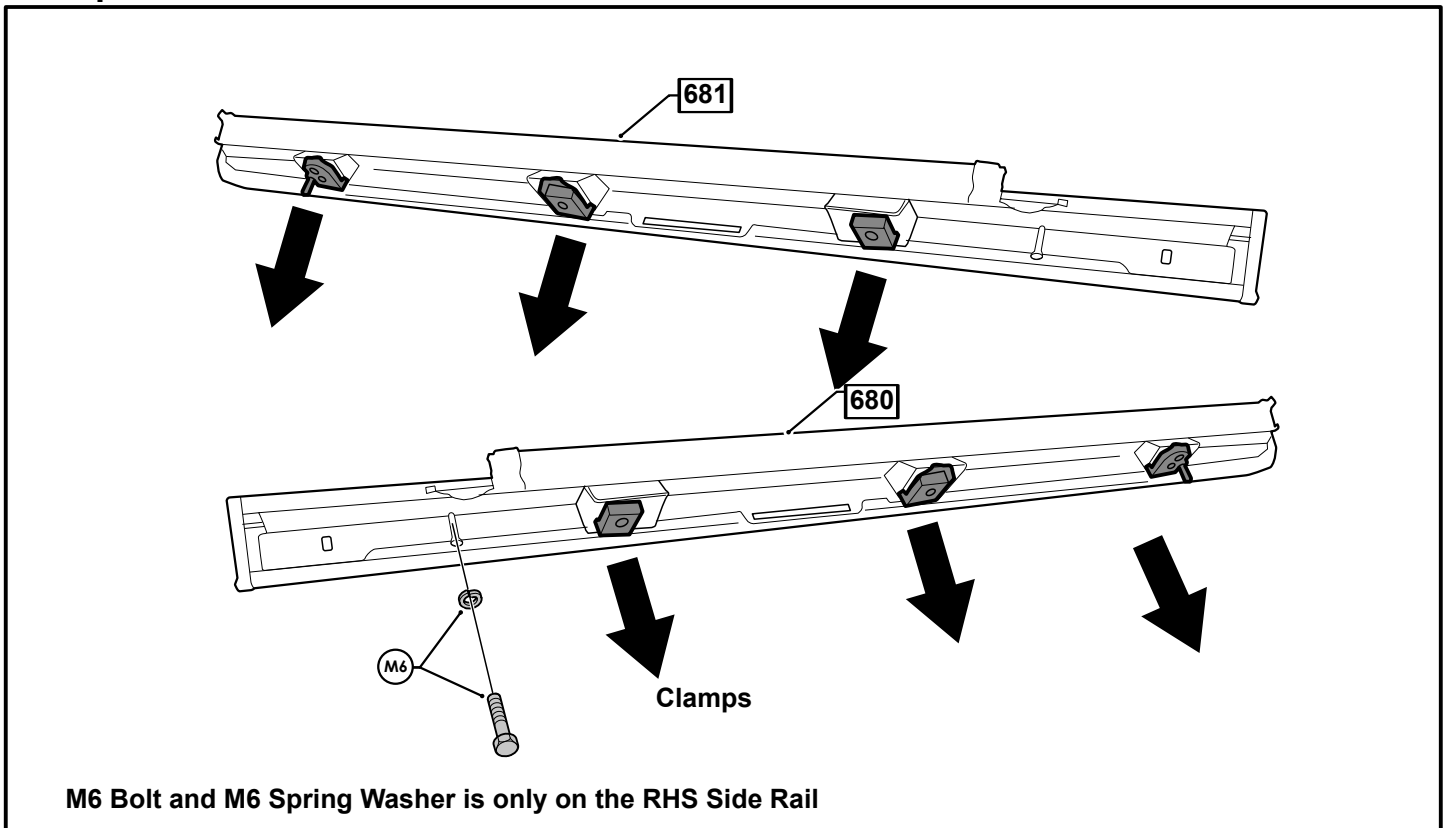

— Step 9

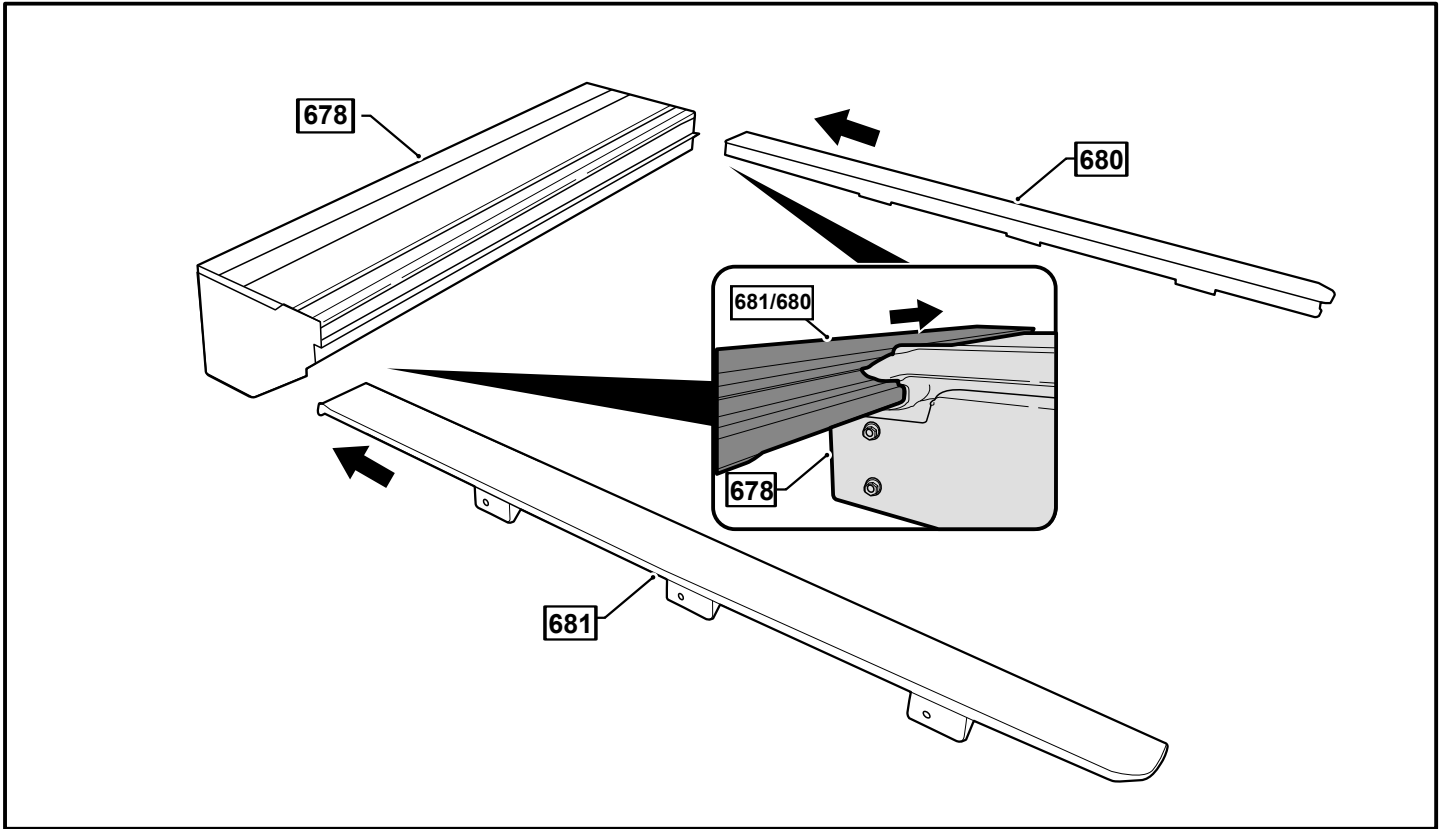

— Step 10

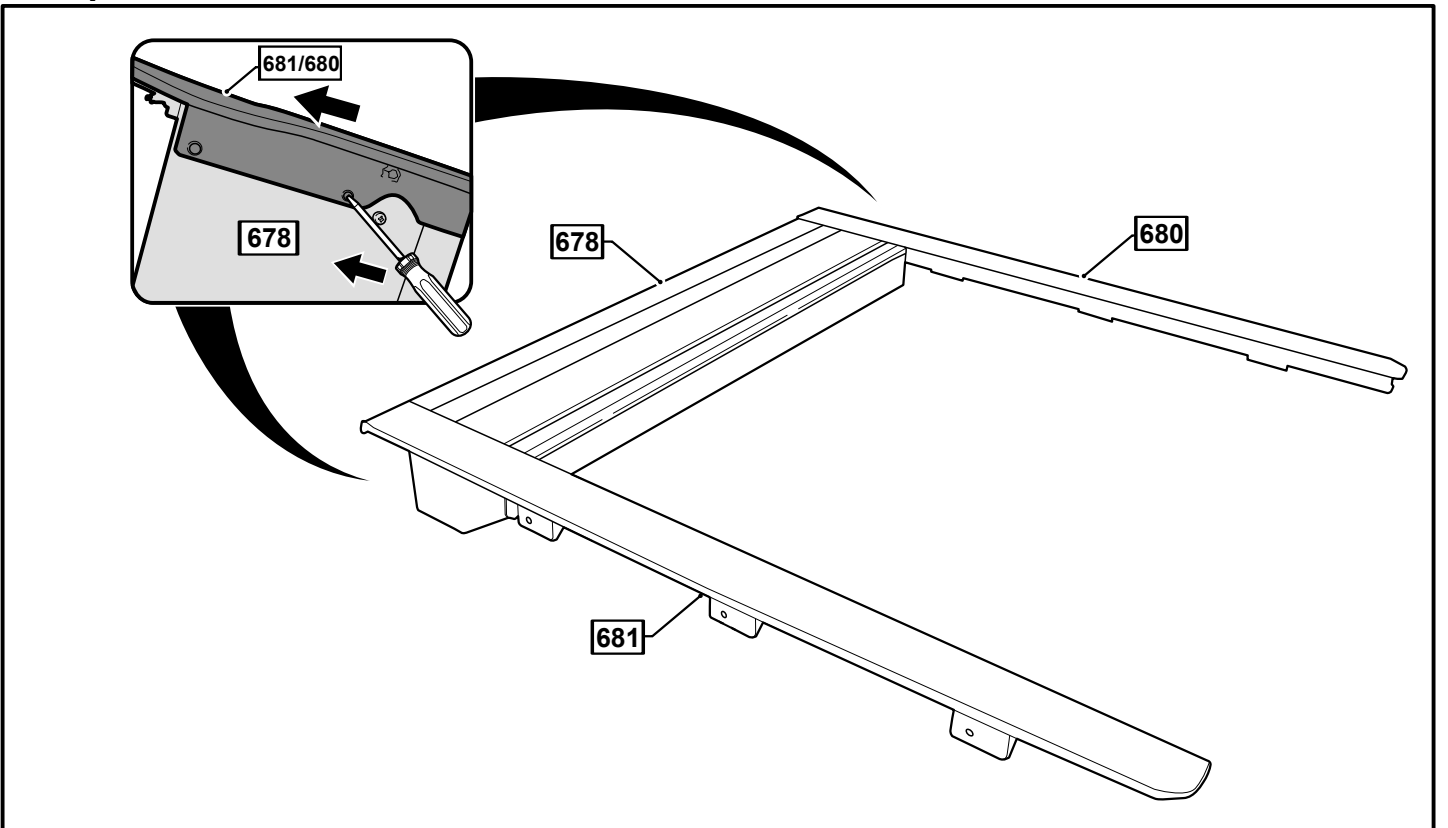

– Step 11

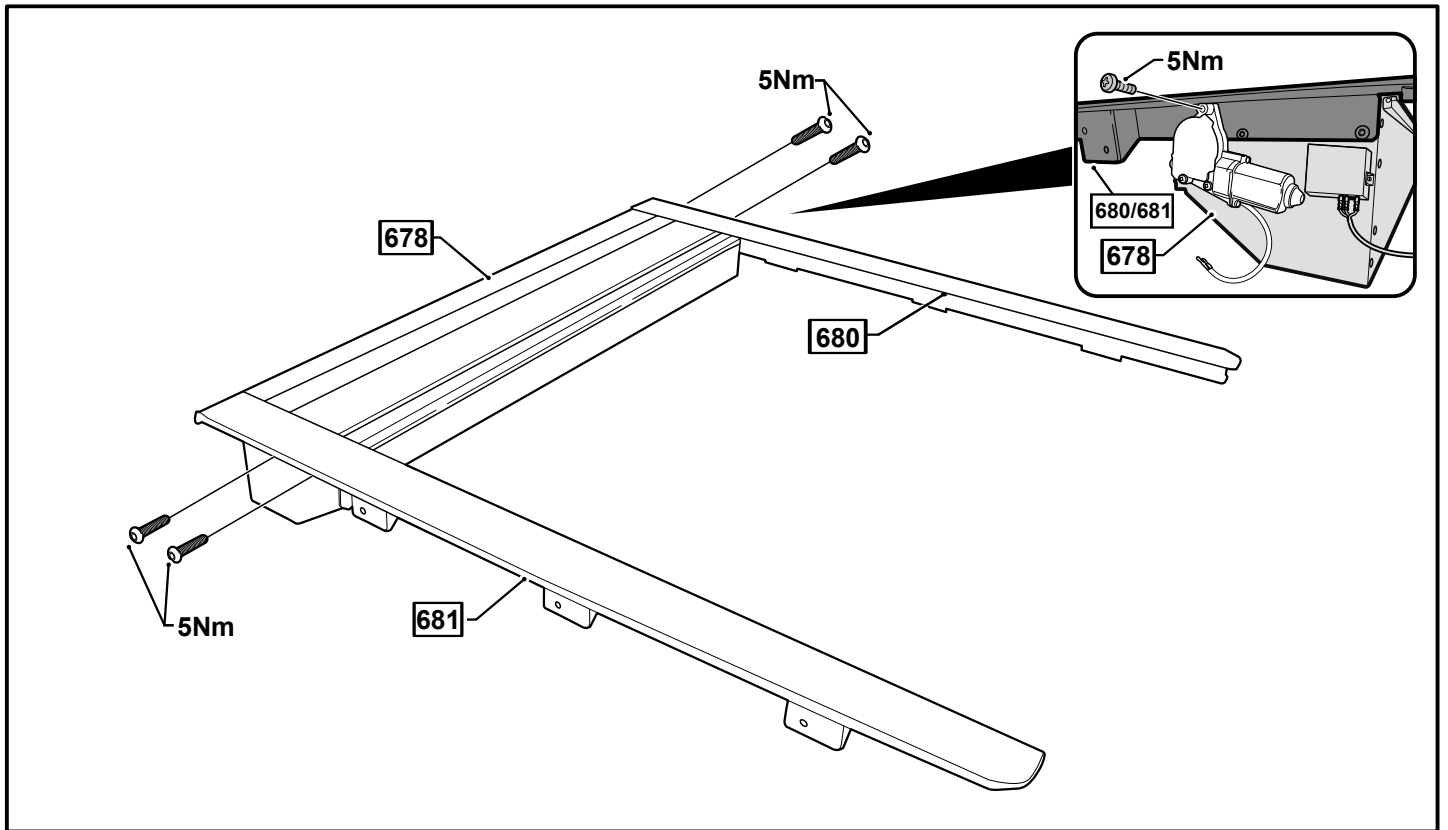

– Step 12

Apply tar sealant to the gap under water channel.

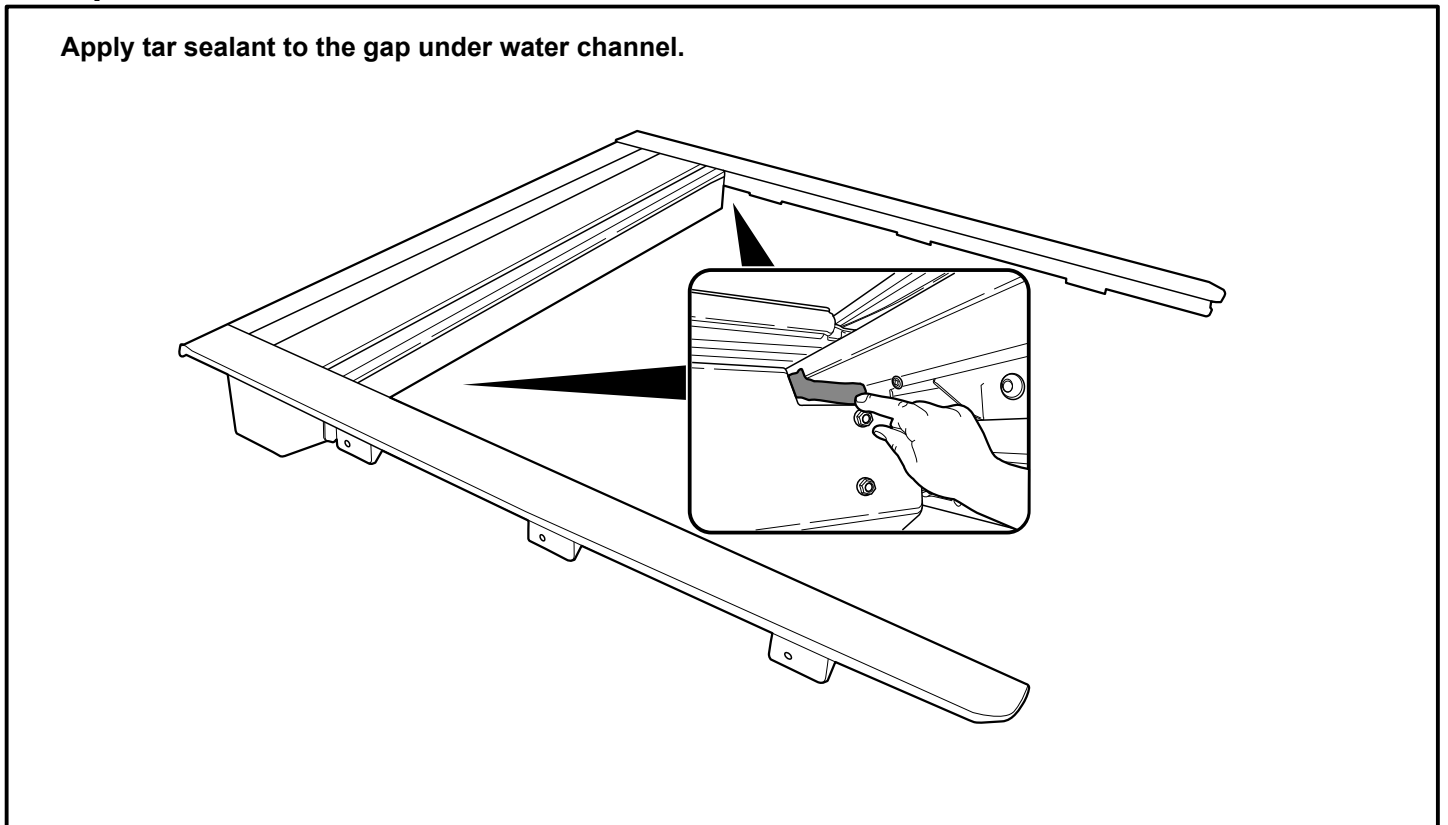

– Step 13

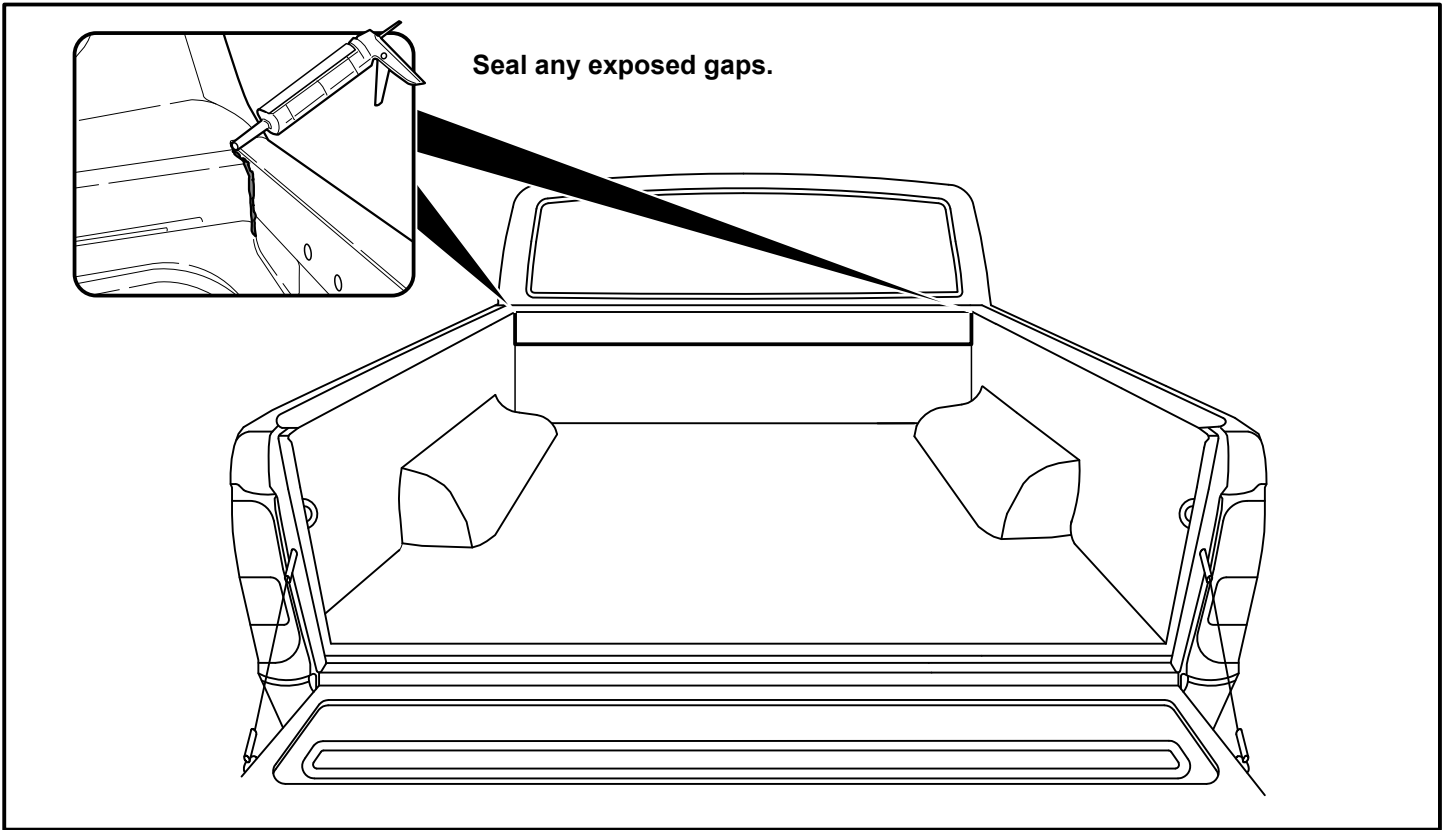

– Step 14

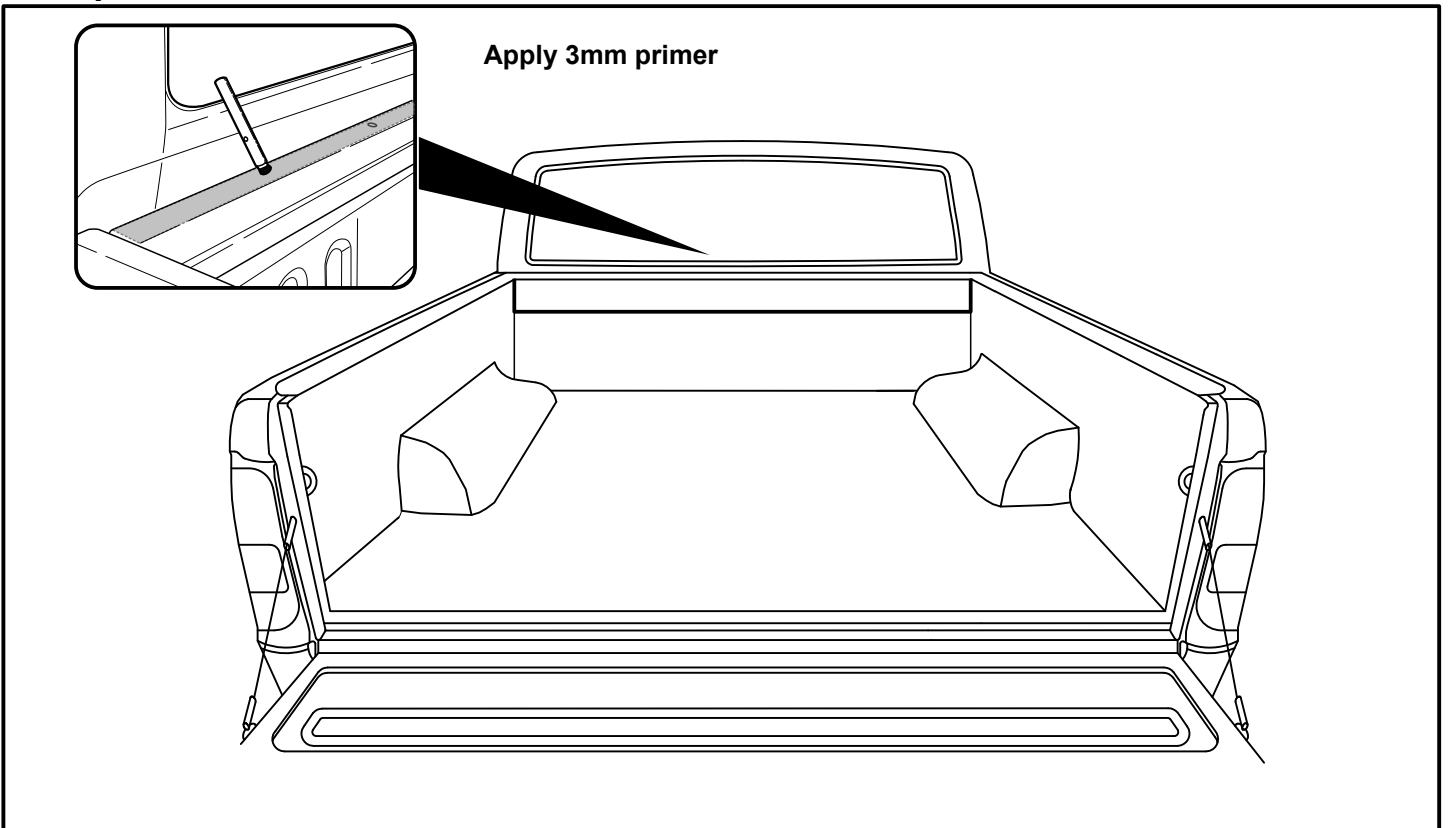

— Step 15 —

Installing the Roll-R-Cover

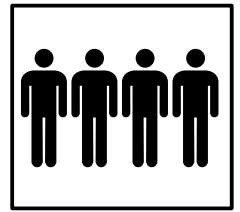
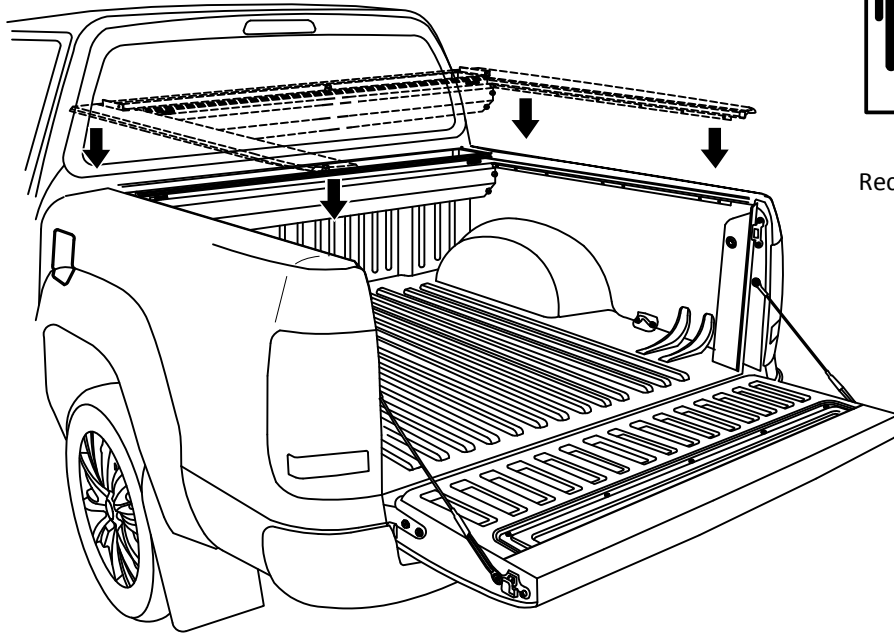

4 People
Recommended for lift

— Step 16 —

Before dropping the Roll R cover into place on the tub, connect all relevant connections or plugs to the receiver and motor plug connection.

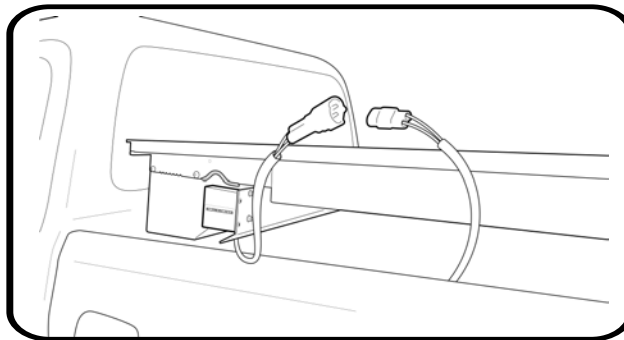
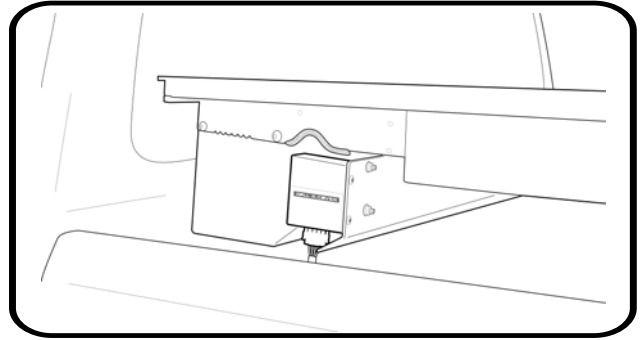
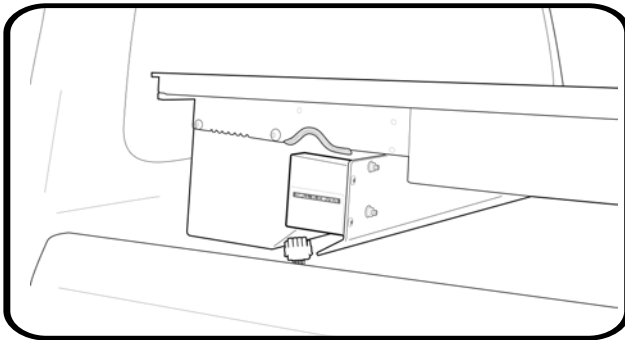

– Step 17

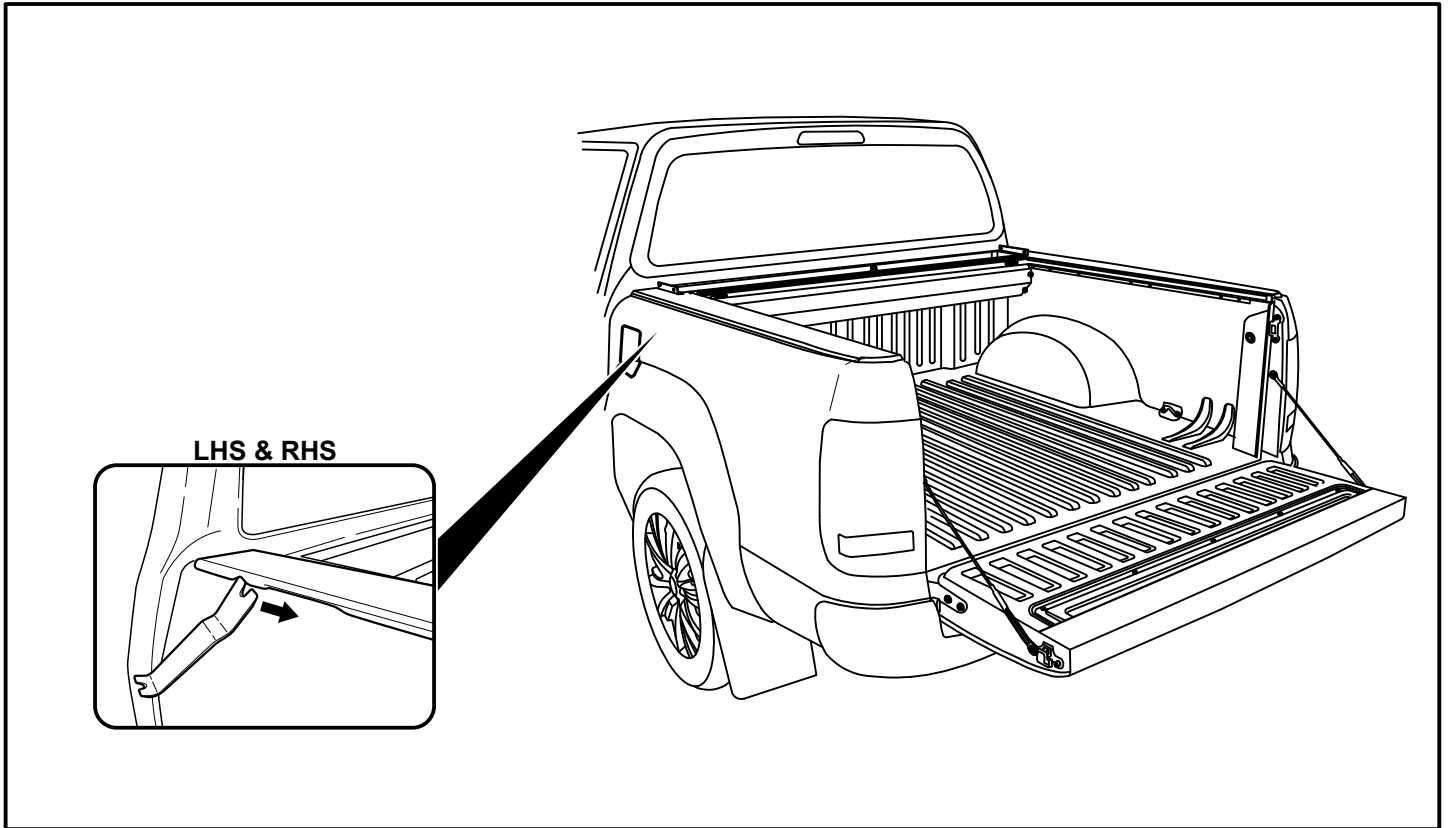

– Step 18

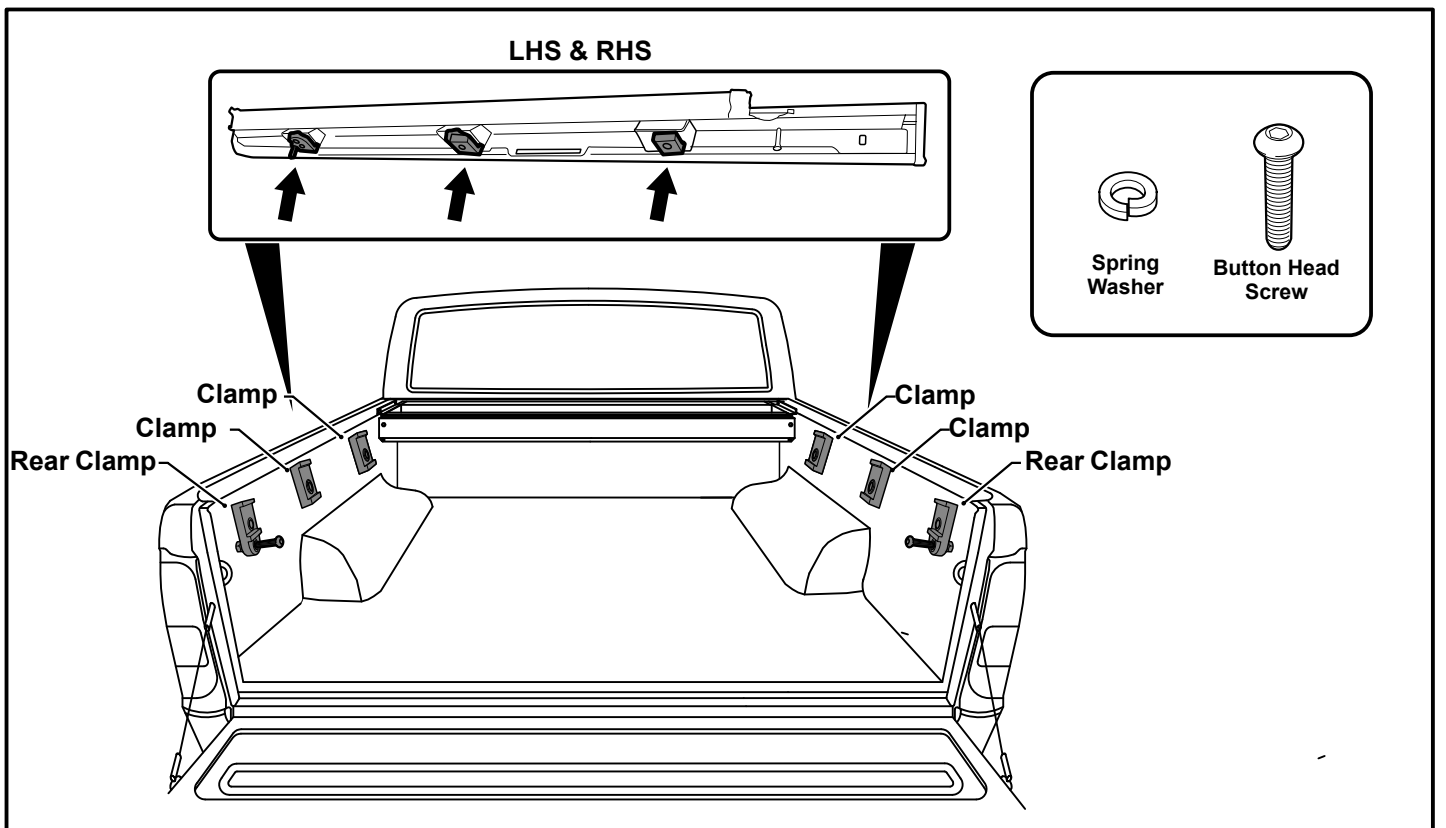

– Step 19

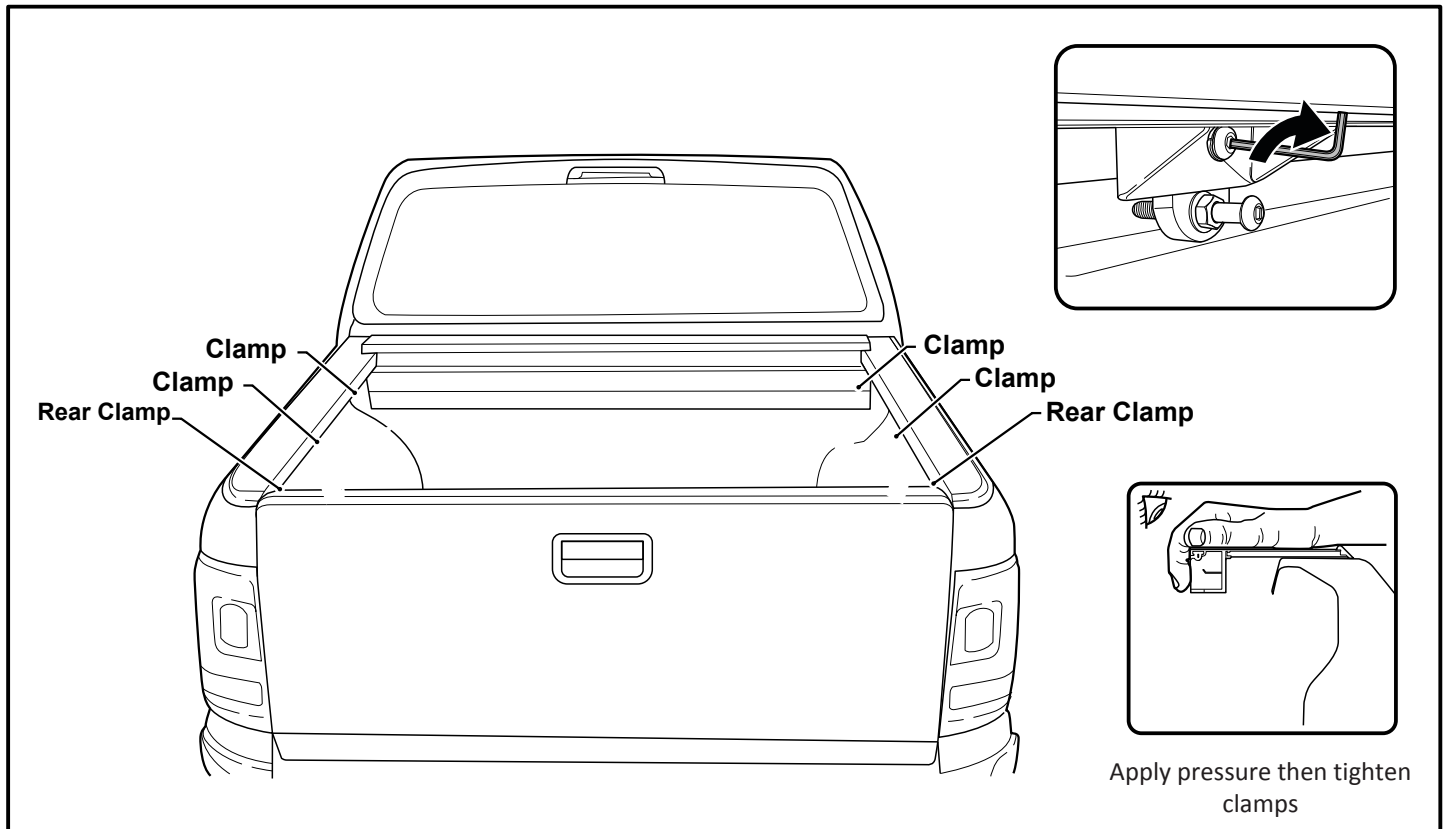

– Step 20

If curtain doesn't meet the tailgate in it's fully closed position, loosen the clamps and shift the unit back.

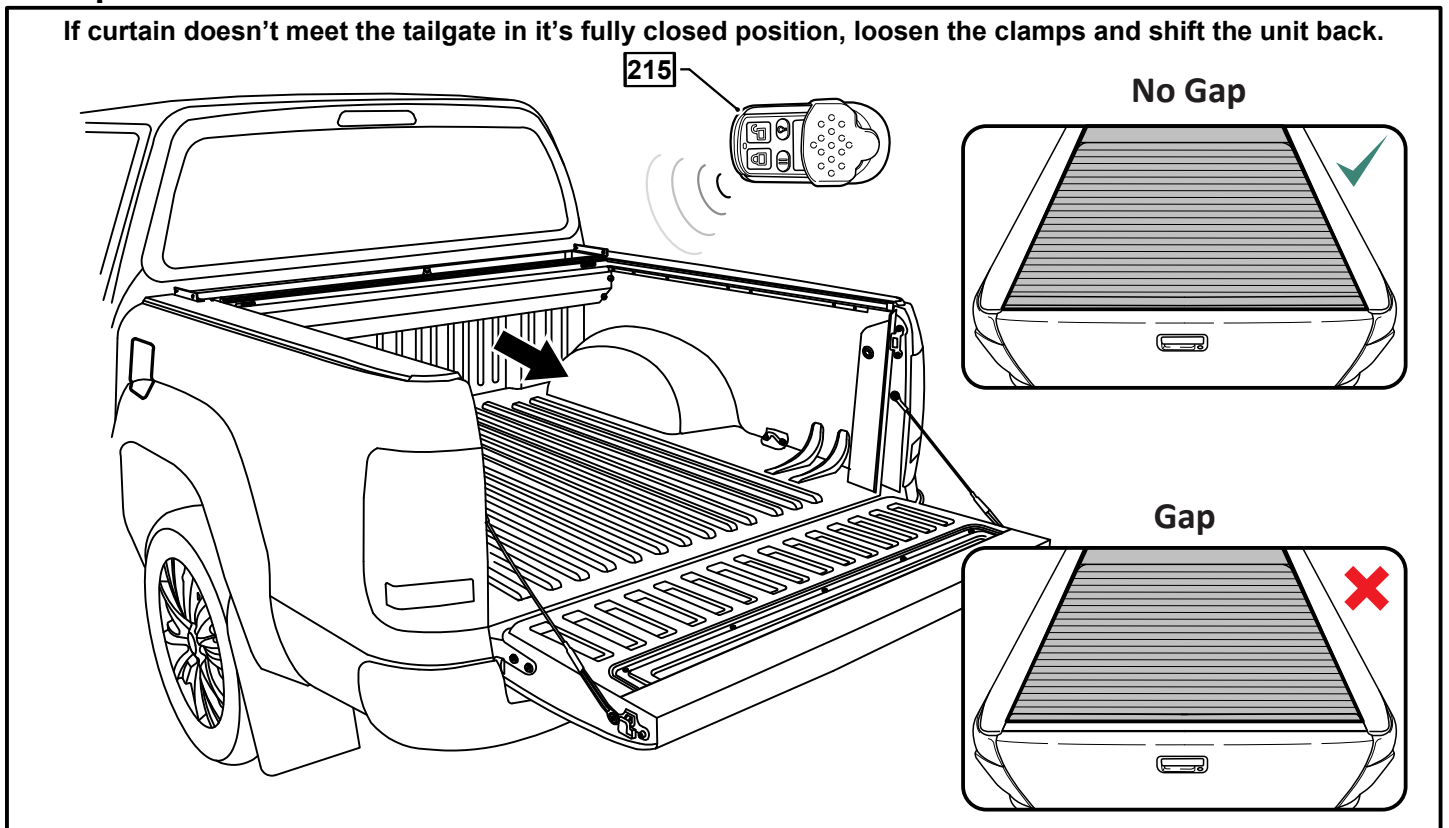

– Step 21

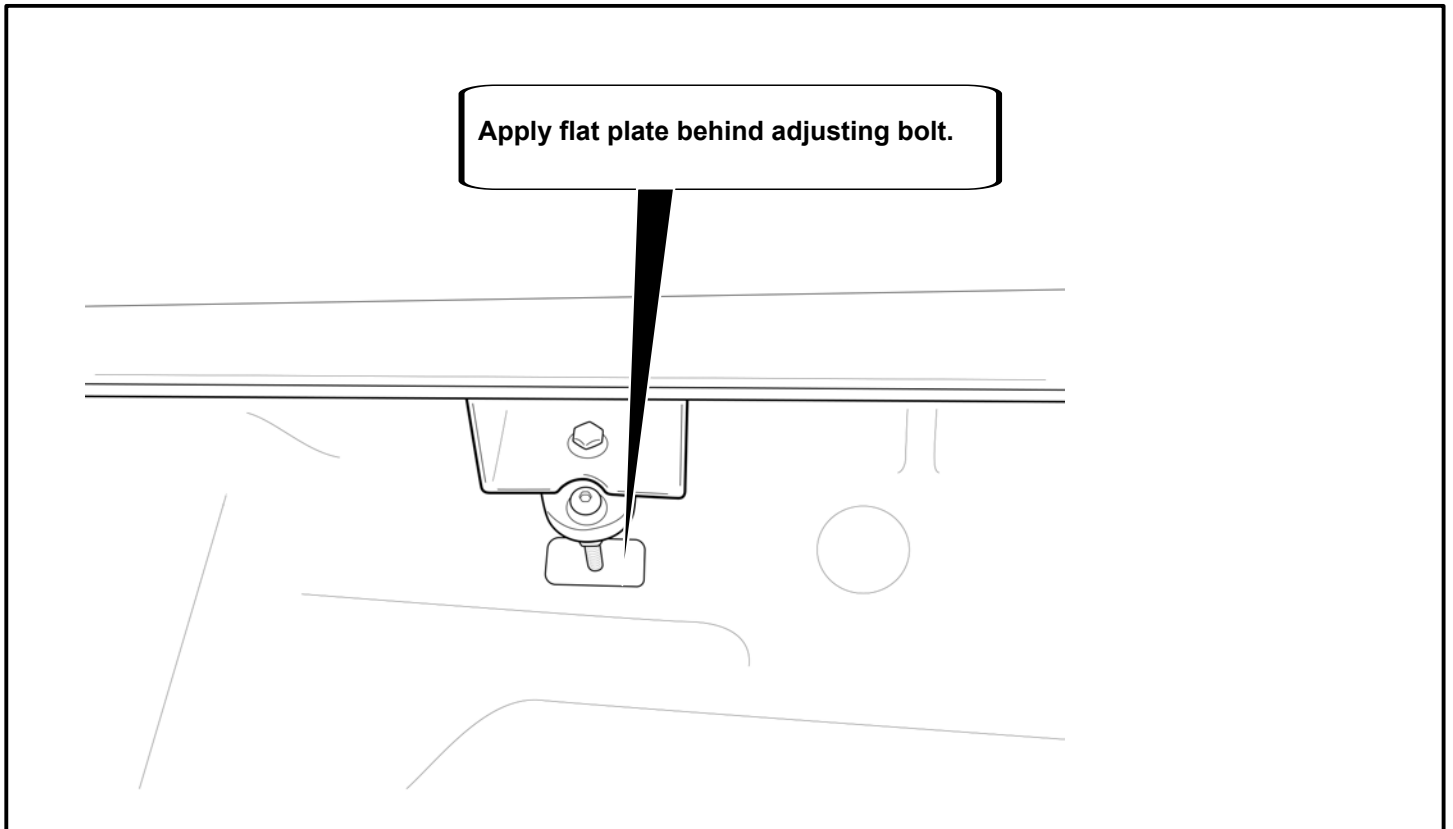

– Step 22

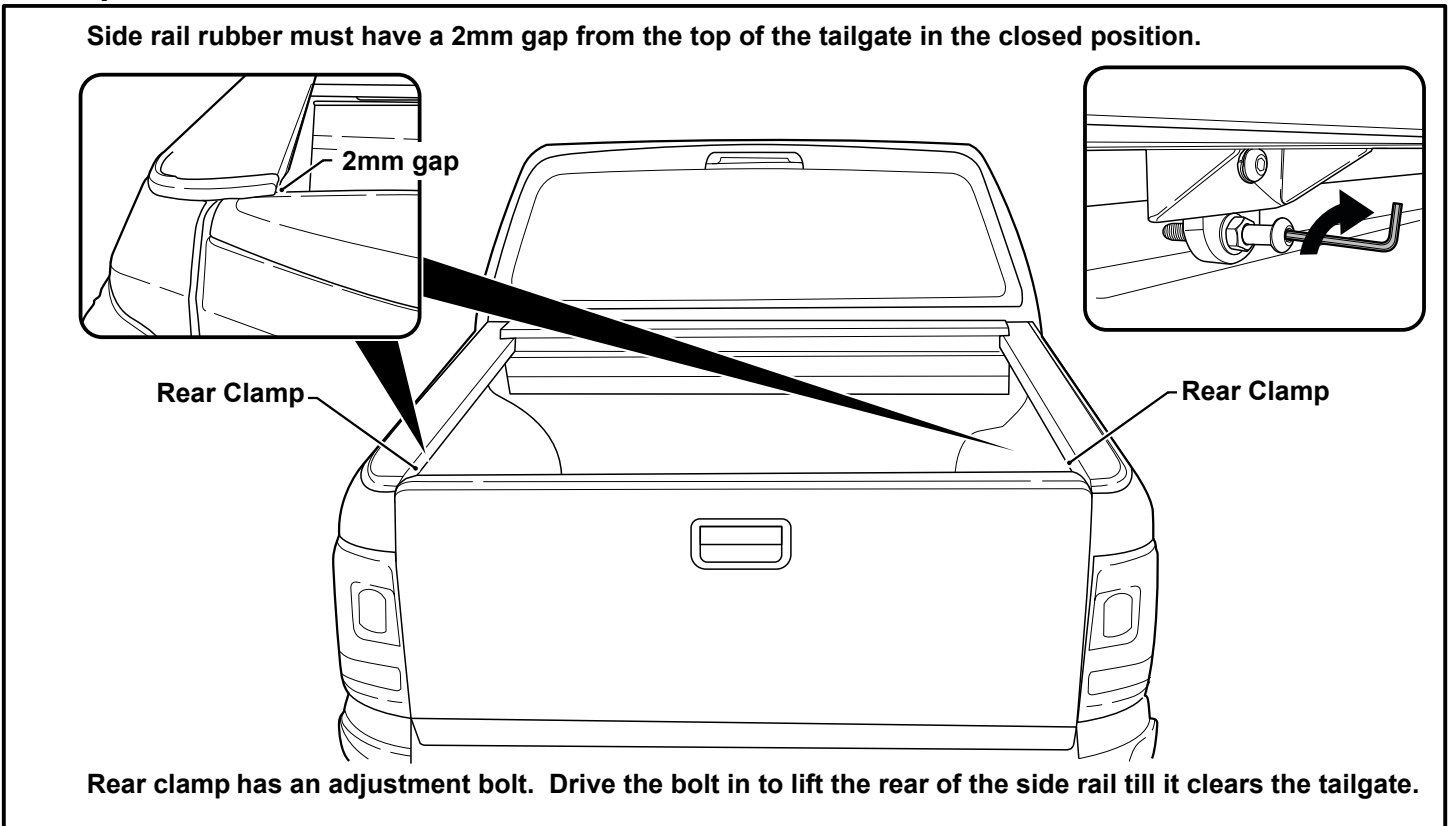

– Step 23

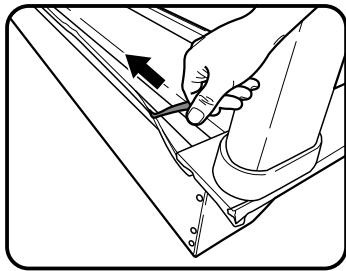

Peel double sided tape backing off and stick to vehicle.

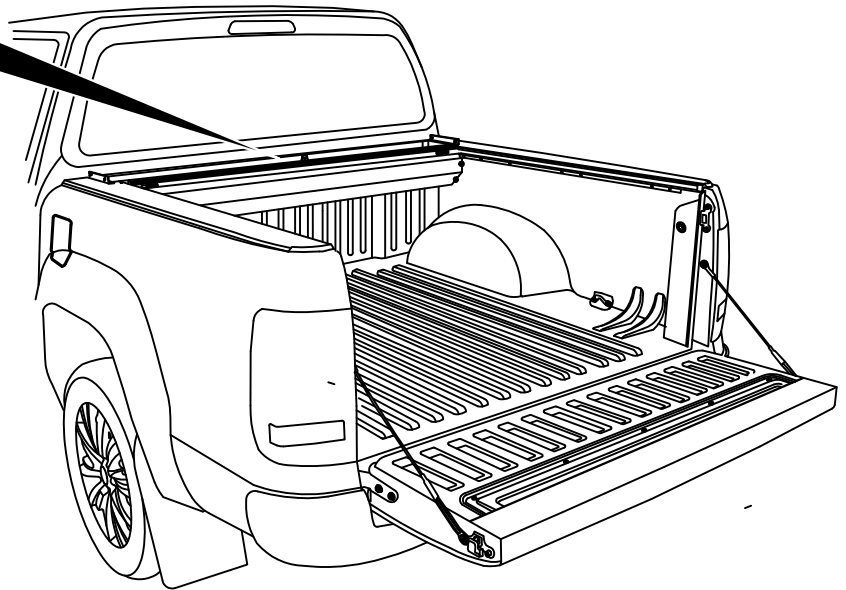

– Step 24

Drill through bed and liner (check for obstructions). Connect the clear drain pipes to the canister and feed through the bed liner making sure to cut the excess to avoid kinks in the pipe.

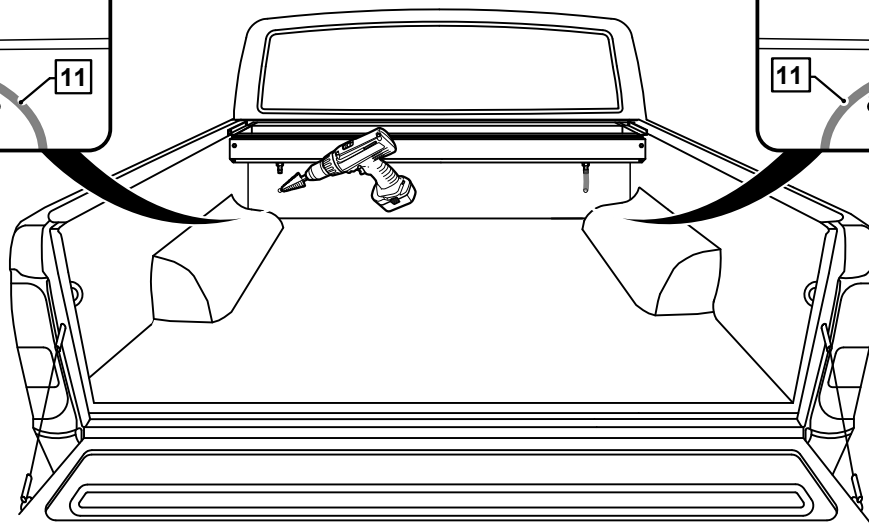
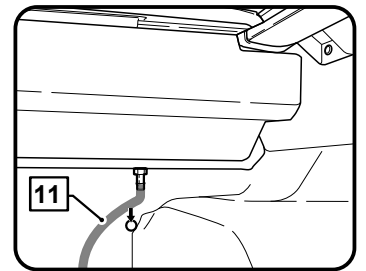
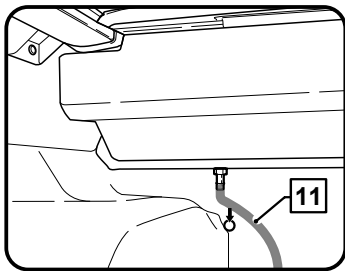

If the vehicle does not have a bed liner, locate the grommets on the lower section front of tub, under the Roll R Cover Canister, make a hole (check for obstructions) and feed through by 10mm. Cut excess off.

– Step 25

Rear drainage: Remove the tail light to check for obstructions before drilling.

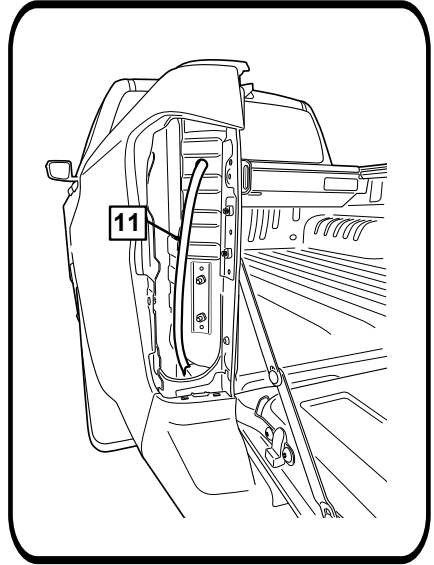
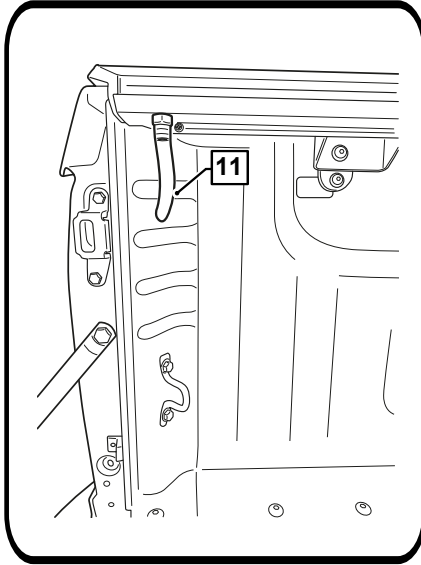
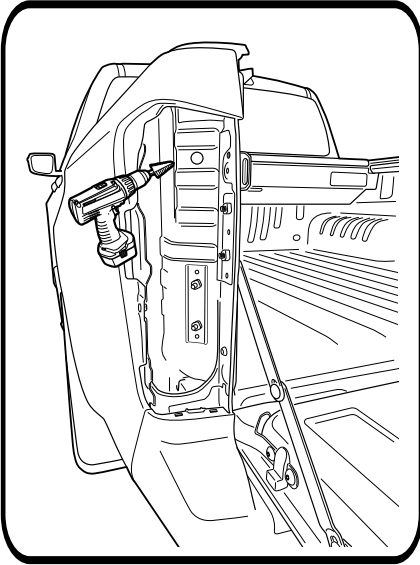

– Step 26

Snap fit the top cover.

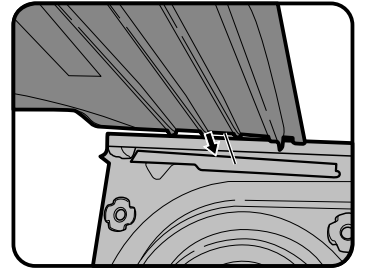
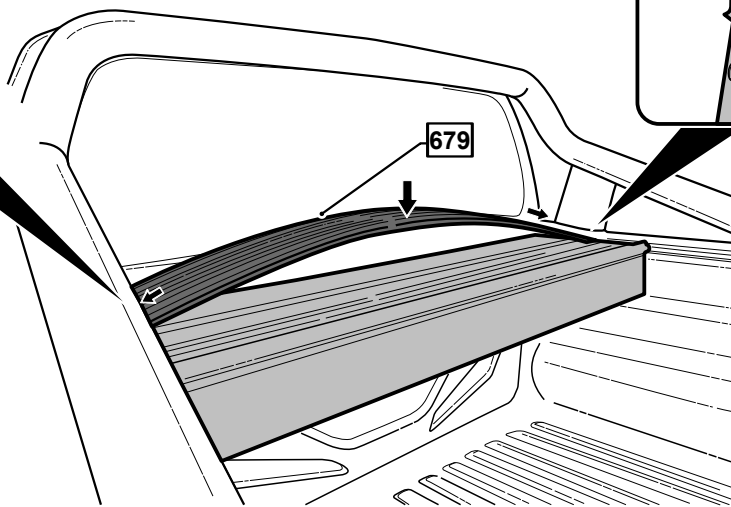
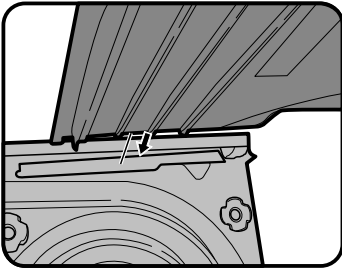

– Step 27 –

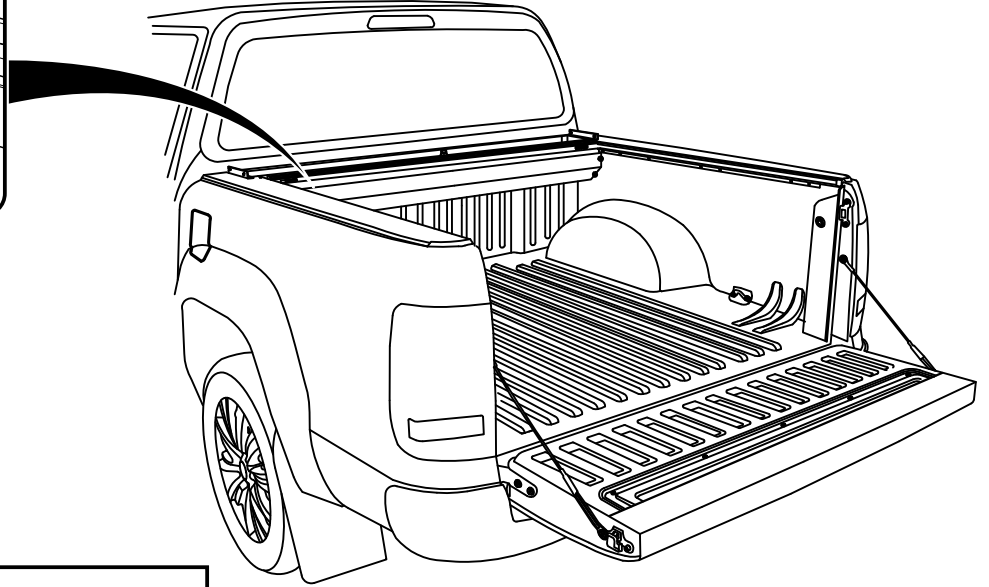
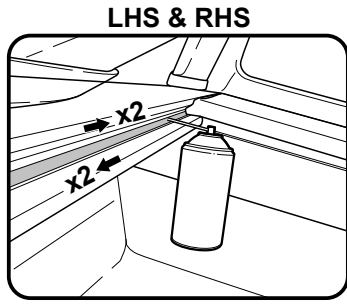

Important



Tracks need to be lubricated regularly

– Step 28 –

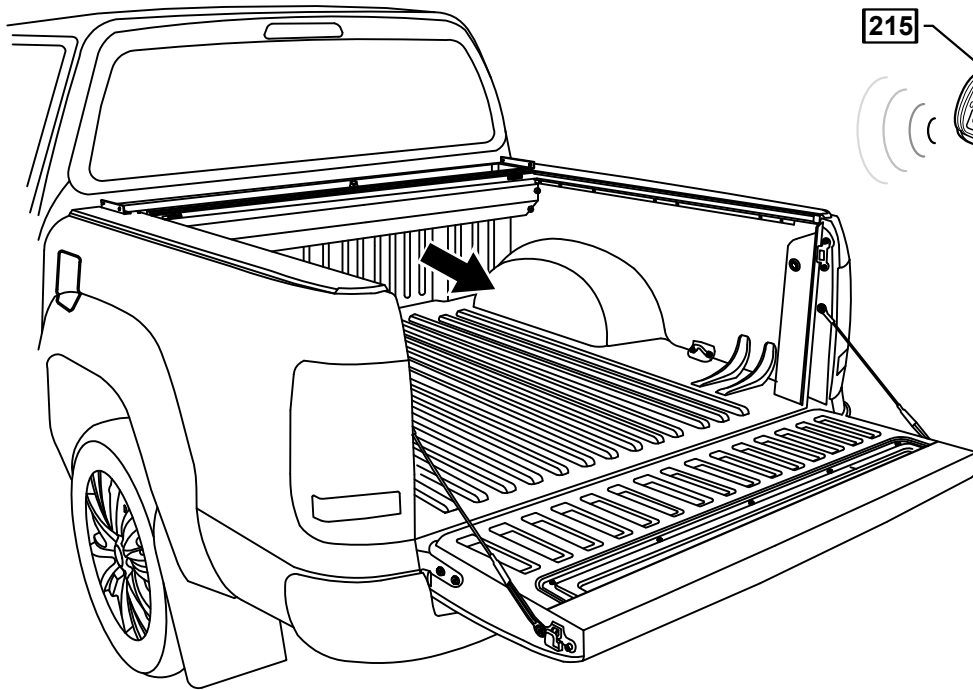

WARNINGS! www.hsputelids.com

 NO STANDING	 ENSURE LOAD IS SECURE	 CHECK GLIDES OIL REGULARLY	 CHECK CLAMPS AND TIGHTEN	 DO NOT PLACE LOAD ON COVER	 CHECK DRAIN	 MECHANICAL HAZARD	 NO PEOPLE OR ANIMALS UNDER ROLL TOP
---	---	--	--	--	---	---	--

E. & O.E. This document is copyright and must not be used except as permitted below or under the Copyright Act 1968. You may reproduce and publish this document in whole or in part for your or your organisation's own personal or internal compliance, educational or non-commercial purposes. You must not alter or amend this document in any way. You must not reproduce or publish this document for commercial gain without the prior written consent of the copyright owner.