

TOYOTA FORTUNER GUN156R MY2015 ON ROCK SLIDERS

IMPORTANT! – READ BEFORE INSTALLATION

- When installed in accordance with these instructions, the front protection bar does not affect the operation of the vehicles SRS airbags.
- This product must be installed exactly as per these instructions using only hardware supplied.
- Take a few moments to read instructions thoroughly before beginning work.
- In the event of damage to any bar component please contact OFFROAD ANIMAL to arrange repair/replacement of components.
- Do not use this product for any vehicle make or model other than that specified on these instructions.
- Do not remove labels from this product.
- This product and its fixings must not be modified in any way unless stated in these fitting instructions.
- The installation of this product is recommended for trained personnel.
- These instructions are correct at time of publication. OFFROAD ANIMAL cannot be held responsible for the impact of any changes subsequently made by the vehicle manufacturer. If you find something has changed please contact us to let us know!
- During installation it is the duty of the installer to check correct operation/clearances of all components.
- If Instructions are to be printed for reference in the workshop, it is recommended that they are printed in colour, for best legibility.

PARTS LISTING

IMPORTANT: Check all parts are present before beginning work! Contact OFFROAD ANIMAL if something is missing.

Bracket Kit Parts – In the Box

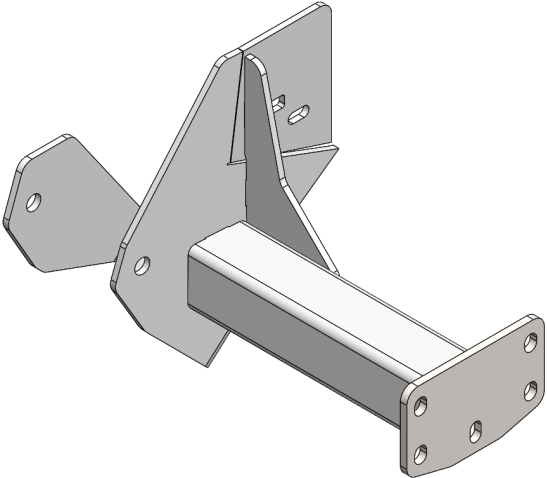
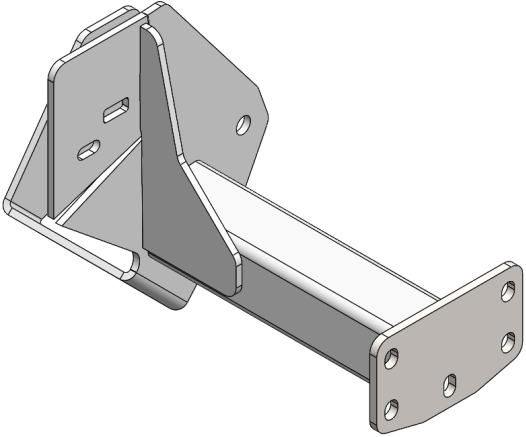
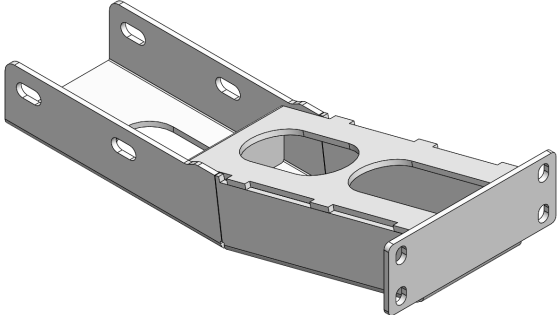
Qty	Part Number	Description	Image
1	RS-TFT-N160-21-ASM1R	Fortuner Slider Rear Chassis Mount	
1	RS-TFT-N160-21-ASM1L	Fortuner Slider Rear Chassis Mount	
2	RS-THL-N80-15-ASM2	Hilux Slider Front Crossmember Mount Assy	

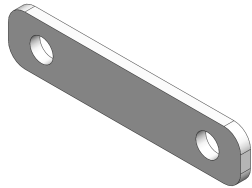
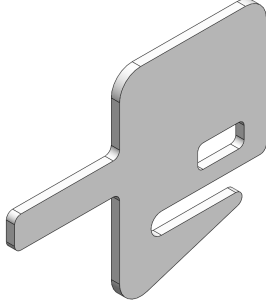
4	P-0107	Front Mount Spacer Plate	
4	P-0271	Fortuner Slider Rear Mount Spacer Plate	

Step Kit Parts – In the Box

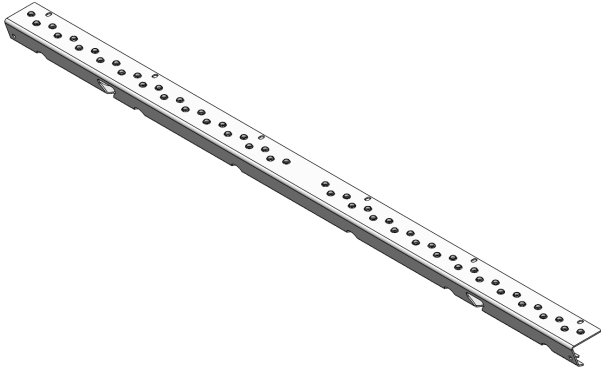
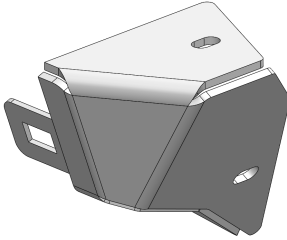
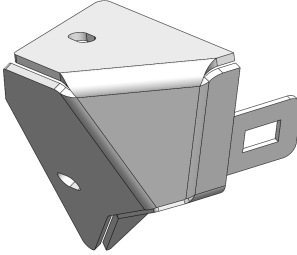
Qty	Part Number	Description	Image
2	B-0852	Slider Step - 1600mm	
2	RS-COM-EC-STB-R	Stub Nose Endcap Outer	
2	RS-COM-EC-STB-L	Stub Nose Endcap Outer	

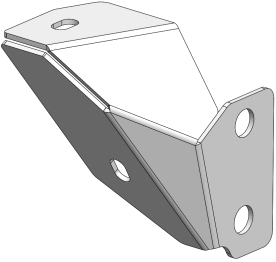
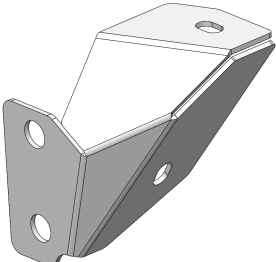
2	B-0801R	Stub Nose Endcap Rear Cover	
2	B-0801L	Stub Nose Endcap Rear Cover	

Step Kit Parts – In the Box

Qty	Part Number	Description	Image
2	E-0002-1600	Slider Extrusion - 1600mm	

Bracket Kit Small Parts – Contained in Small Parts Kit Bag

Qty	Part Number	Description
6	M12 x 130	Bolt Hex, M12X130x1.75, GR8.8 ZP
2	M12 FW LHD	M12 FW Large Heavy Duty
4	M12 FLAT WASHER	M12 FW
2	NP-COM-M12-300-ASM0	M12 NUT PLATE 300MM STEM
16	M10 x 25	Bolt Hex, M10X25x[1.5], GR8.8 ZP
16	M10 FLANGE NUT	Flange Nut, M10x1.5 G8.8 ZP
1	M8 X 35 HEX	Bolt Hex, M8X35X1.25, GR8.8 ZP
1	M8 HD FLAT WASHER	M8 FLAT WASHER - High Tensile 19x8x1.9mm
1	NP-COM-M8-210-ASM0	M8 Nut Plate 210mm
4	P-0301	M12 Open Slot Spacer Washer 2mm
2	T-0059	Fortuner Slider Rear Crush Tube 91mm

Step Kit Small Parts – Contained in Small Parts Kit Bag

Qty	Part Number	Description
12	M6x16 BHCS BLACK ZINC	SCREW, BUTTON HEAD CAP, M6X16X1 GR12.9, ISO4042 ZnNi BLACK PASSIVATED FINISH
12	M6 FLAT WASHER BLACK ZINC	M6 Flat Washer, 12x6.1x1, ISO4042 ZnNi BLACK PASSIVATED FINISH
8	M6 FLANGE NUT	Flange Nut, M6x1 G8.8 ZP
4	M6CN3MM	CAGE NUT M6x2.6-3.5
12	M8 X 20 BHCS BLACK ZINC	SCREW, BUTTON HEAD CAP, M8X20X1.25 BLACK ZP
12	M8X20 CAP SCREW	CAP SCREW, M8X20X1.25 GR10.9 ZP
24	M8 FLAT WASHER BLACK ZINC	M8 FW- BLACK ZINC
24	M8 NUT	Hex Nut, M8x1.25 G8.8 ZP
8	M10x15 BHCS	SCREW, BUTTON HEAD CAP, M10X16X1.5 GR12.9 ZP
8	M10 Flat Washer	M10 FW
8	M10 NUT	Hex Nut, M10x1.5 G8.8 ZP
2	OFA-LOGO	OFFROAD ANIMAL METAL LOGO



TOOLS REQUIRED

The following tools will be required to install the product.

Hand Tools	Power Tools	Workshop Equipment
Metric Socket Set 10mm,12mm,15mm,16mm,17mm,18mm,19mm Socket Extension Bar Metric Spanner Set 10-19mm Hex (Allen) Key Set 4-6mm Flat Blade Screwdriver Rubber Mallet Soft Clamps	Electric/Air Impact Driver (Optional)	Hydraulic Floor Jack

WORKSHOP SAFETY

It is the responsibility of the installer to always complete works in a safe manner. Make sure the following safety equipment is available and precautions are observed whilst fitting this product.

<p>Hearing Protection</p> 	<p>Always wear ear protection when using power tools.</p>
<p>Eye Protection</p> 	<p>Ensure eye protection is always worn when cutting or drilling.</p>
<p>Manual Handling</p> 	<p>Do not attempt to lift bar assemblies or rock sliders on your own.</p> <p>Always use two people to lift or use mechanical Lifting aid such as hydraulic lifting trolley.</p>
<p>Vehicle Support</p> 	<p>Always ensure vehicle is properly supported when working on it. Do not attempt to fit products whilst suspension work is being carried out. Do not work under a vehicle supported only by a jack.</p>

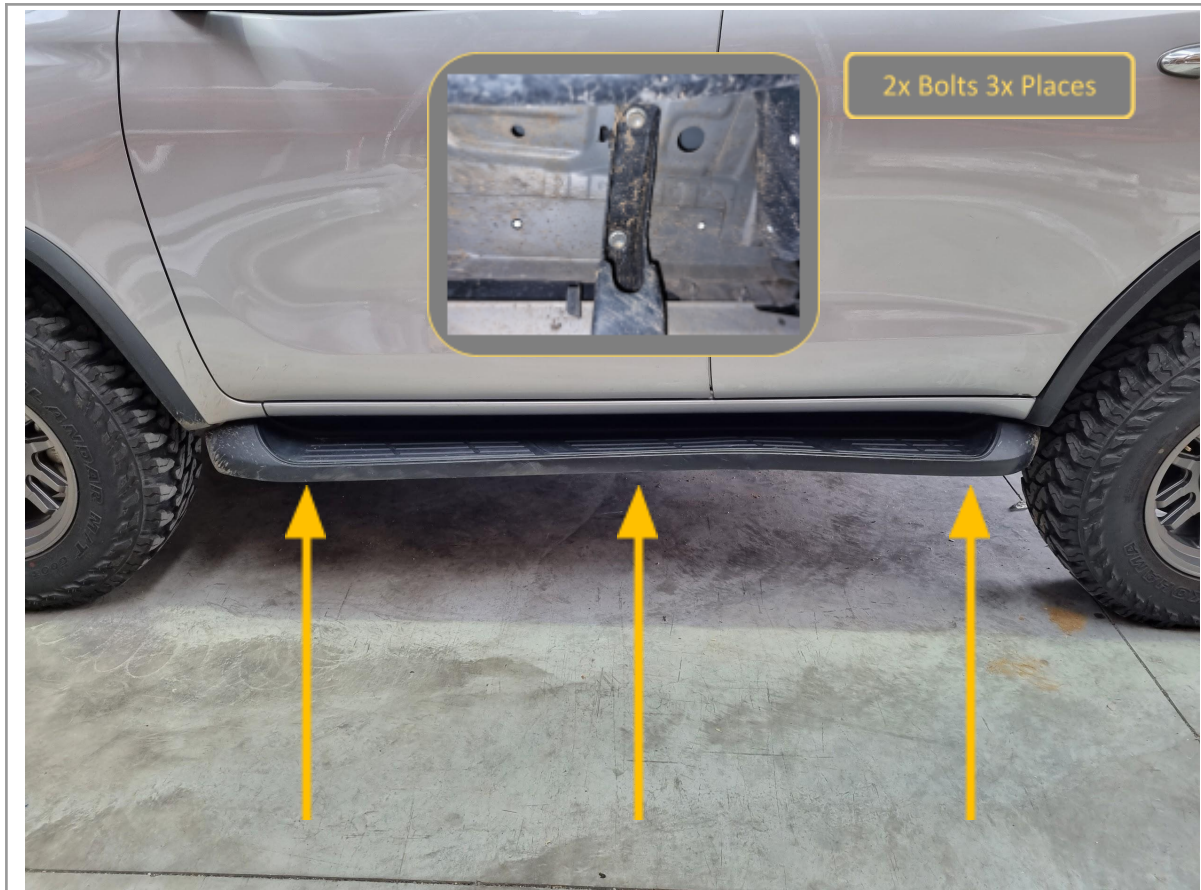

1. Remove Factory side steps if fitted by removing the 6x Bolts (2 Per mount) securing them to the body using a 12mm socket.
2. Discard Factory steps and bolts.

TOOLS REQUIRED
12mm socket

FASTENERS
6x Factory Flange head Bolts (per side)

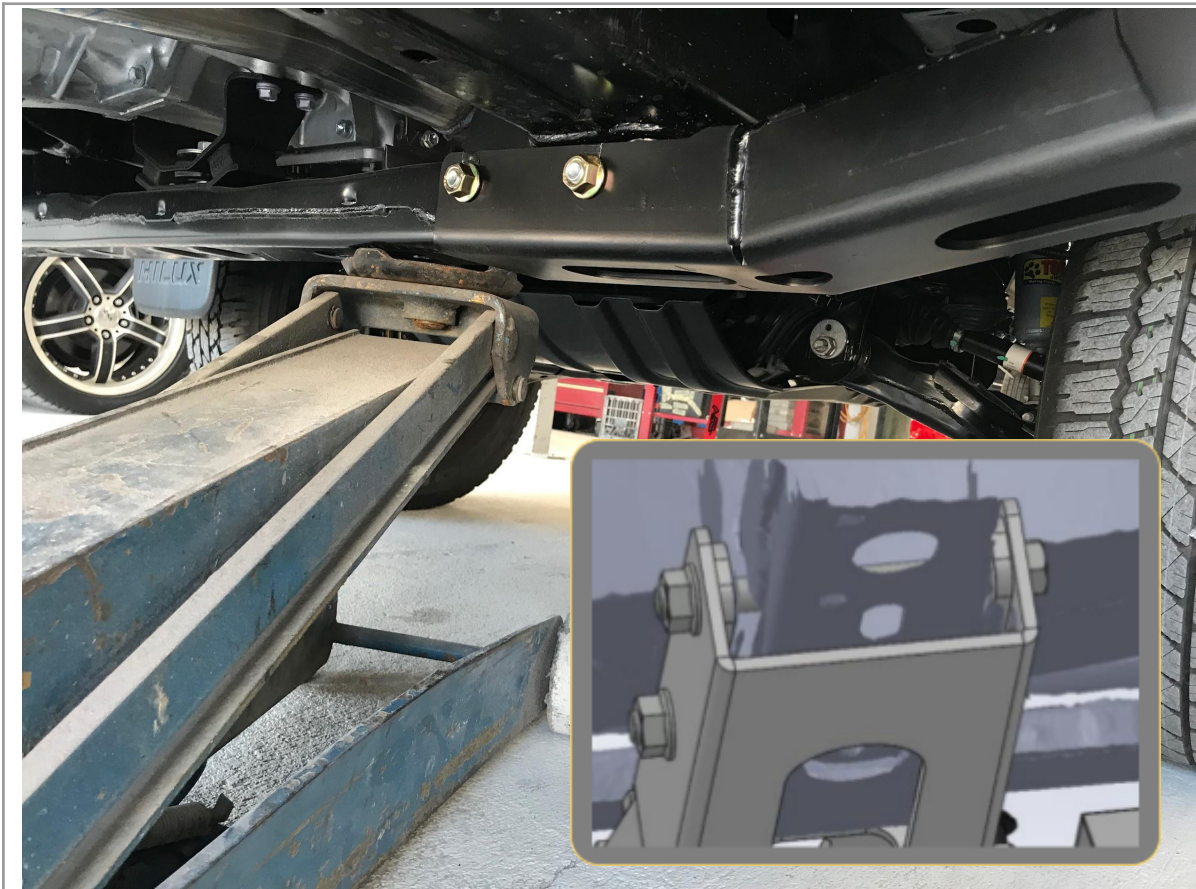

3. Installation of the front bracket is as shown. Locate the area around the gearbox cross member on the RHS of the vehicle.
4. Using a hydraulic jack, support the gearbox cross member. Place enough pressure on the cross member so that the body of the vehicle lifts slightly.
5. Remove and discard the factory M12 bolts securing the gearbox cross member to the chassis rail.
6. Fit the front mount bracket over the cross member, with P-0107 spacer plates taking up the gap between the cross member and bracket, as per the inset image.
7. Ensure the front mount is sitting flush with the cross member. Once positioned, tighten M12 bolts, and release the jack off the vehicle.

TOOLS REQUIRED

18mm socket/ spanner

Hydraulic floor jack

FASTENERS

2x M12 x 130 hex bolt

2x M12 flat washer

2x M12 flange nut



8. Installation of the rear bracket is as shown. Locate the area of the chassis below the rear passenger door, near the suspension pickup point.
9. Fit the rear mount bracket with 1x M12x130 hex bolt, heavy duty washer, crush tube 91mm and flange nut through the large opening on the chassis, as indicated by the arrow above.
10. Feed 1x M8 nutplate through the rectangular opening in the chassis (see bottom inset), then secure with 1x M8x35 hex bolt and heavy duty washer.
11. If required, insert any combination of P-0271 and P-0301 shim plates (see top inset) to get the rear mount to sit at a similar height away from the sill as the front mount.
12. Once positioned and shimmed correctly, tighten all bolts.

TOOLS REQUIRED

- 13mm socket/spanner
- 18mm socket/ spanner

FASTENERS

- 1x M12x130 hex bolt
- 1x M12 heavy duty FW
- 1x crush tube 91mm
- 1x M12 flange nut
- 1x M8x35 hex bolt
- 1x M8 heavy duty FW
- 1x M8 nutplate



13. Repeat install steps 3-7 for the front mount on the LHS of the vehicle.
14. For the rear mount on the LHS, instead of using an M8 nutplate, remove the factory M8 flanged bolt securing the handbrake cable to the chassis with a 12mm socket/spanner.
15. Fit the rear mount onto the chassis, then re-use the factory M8 bolt and position the handbrake cable back in the same location through the keyed holes in the bracket.
16. Repeat steps 9,11 & 12 to complete fitment of the rear mount bracket.

TOOLS REQUIRED

- 12mm socket/spanner
- 18mm socket/ spanner

FASTENERS

- 1x Factory M8 bolt
- 1x M12x130 hex bolt
- 1x M12 heavy duty FW
- 1x crush tube 91mm
- 1x M12 flange nut

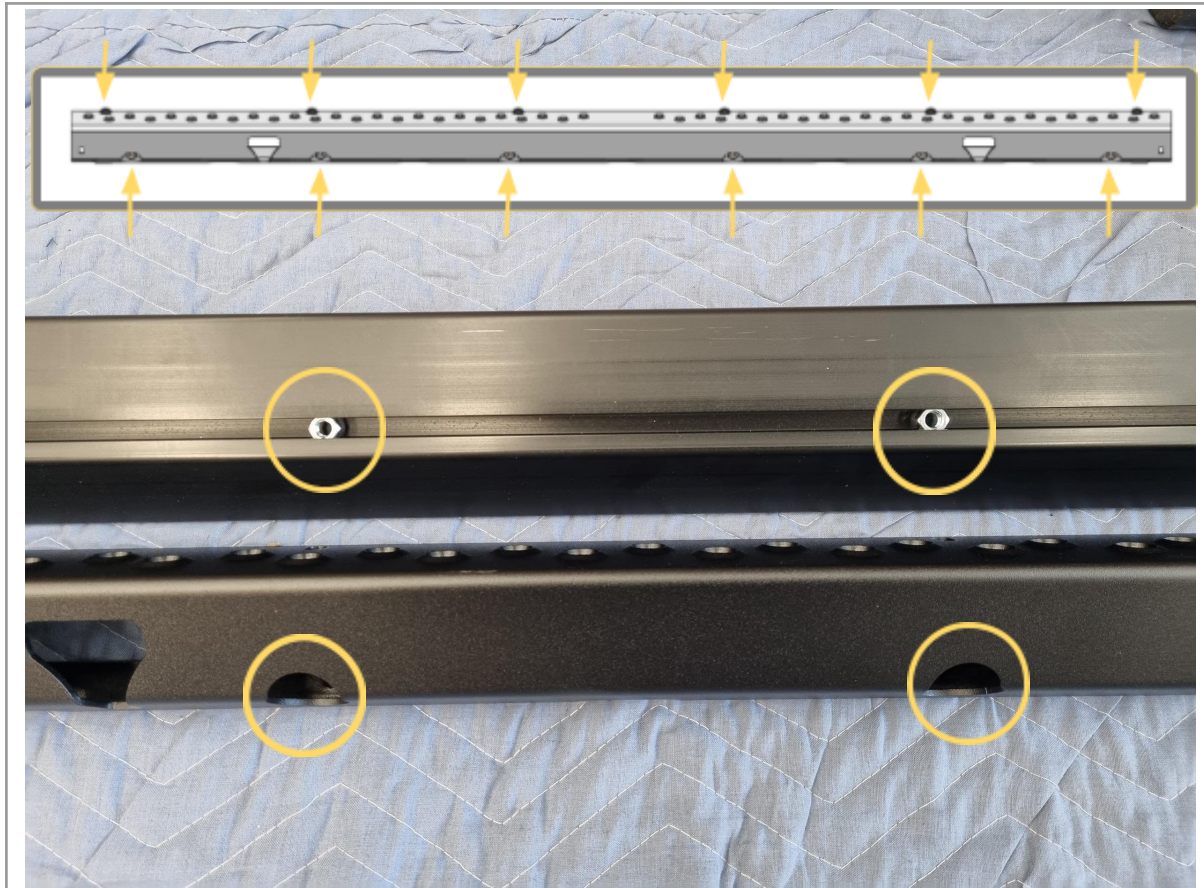

17. Find an open space and place the step in line with the slider extrusion.
18. Feed M8 nuts through the top and outside slots in the extrusion and carefully line them up with the corresponding mounting holes in the step. There are 6x nuts for the top slot and 6x nuts for the outside slot.

TOOLS REQUIRED

FASTENERS

12x M8 Nut



- 19. Fit the step onto the slider extrusion.
- 20. Use M8x20 black button head screws, black M8 washers and M8 Nuts on 6x locations on the top row of the step.
- 21. Use M8x20 cap head screws, M8 washers and M8 nuts on 6x locations on the bottom side of the step.

TOOLS REQUIRED

FASTENERS

- 6x M8x20 black button Head
- 6x M8x20 cap head
- 12x M8 Black Washer

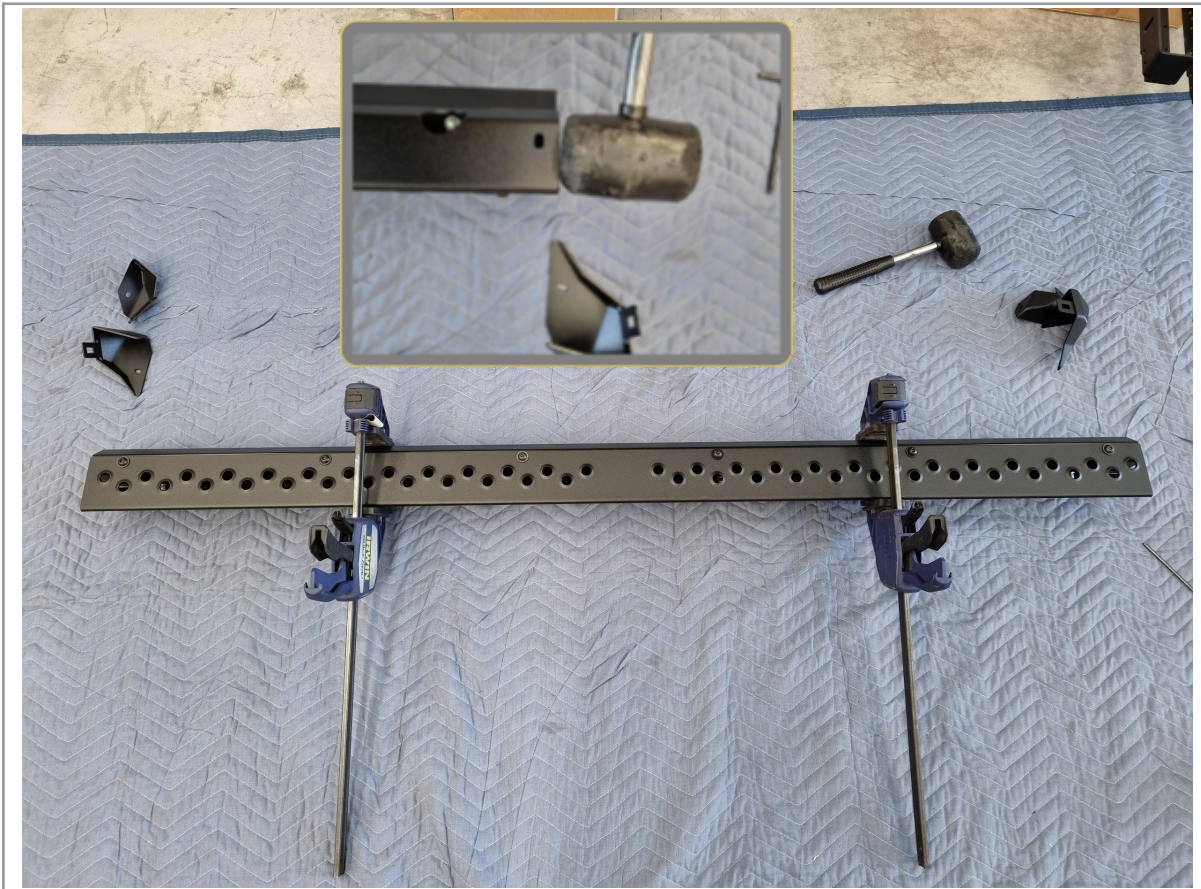

- 22. Adjust the position of the step on the slider extrusion so it is central.
- 23. Clamp the step to the extrusion with a set of soft clamps to ensure they are pressed firmly up against each other.
- 24. Once happy with the alignment, tighten all bolts on slider extrusion, using a 5mm and 6mm hex key.

TOOLS REQUIRED

Rubber mallet

Soft Clamps

5mm Hex key

6mm Hex key

FASTENERS



- 25. Insert 1x M6 cage nut in the rectangular slot of the outer section of the stub nose endcap with a flat blade screwdriver.
- 26. Assemble the corresponding endcap rear cover to the outer section and secure with 2x M6x20 black button head screws, black washers and flange nuts. Leave finger tight at this stage.

TOOLS REQUIRED

Flat blade screwdriver

FASTENERS

2x M6x20 black button head
2x M6 black washer
2x M6 flange nut
1x M6 cage nut

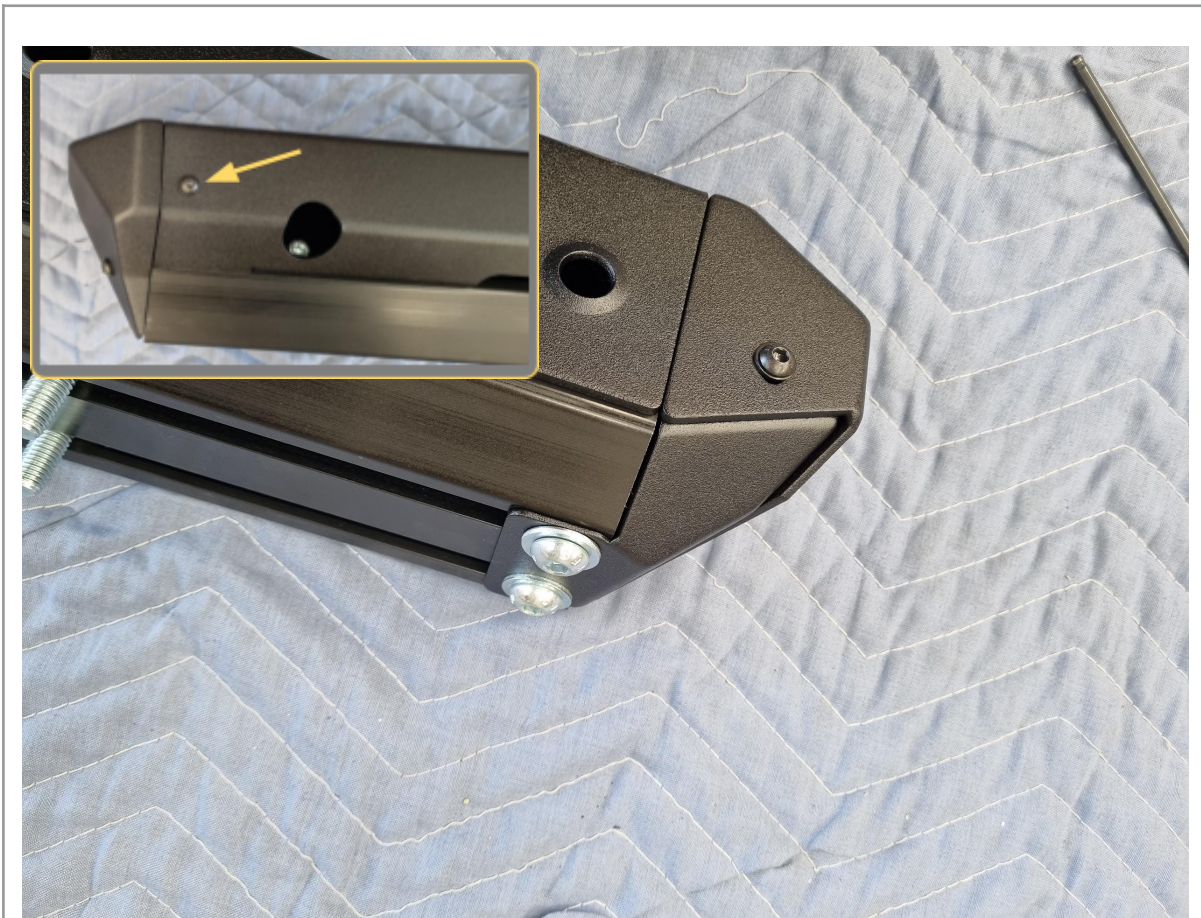

- 27. Slide 2x M10 Hex nuts into the T slots on the back side of the extrusion. (1 per slot)
- 28. Fit the end cap to the end of the extrusion.
- 29. Secure with M10x15 button head screws and washers on T slot nuts and M6x20 black button head and washer on the outside, through the step plate. Tighten bolts once aligned properly.

TOOLS REQUIRED

- 4mm Hex key
- 6mm Hex key

FASTENERS

- 2x M10x15 button head
- 2x M10 flat washer
- 2x M10 hex nut
- 1x M6x20 black button head
- 1x M6 black washer



- 30. Slide 8x M10x25 Hex bolts into the T slots on the back side of the extrusion. 4 bolts per slot.
- 31. Loosely arrange the bolts in 2x groups of 4, in approximate location of mounts on the two ends.
- 32. Fit the mirrored end cap to the remaining end of the slider, as per install steps 25-29.

TOOLS REQUIRED

- 4mm Hex key
- 6mm Hex key

FASTENERS

- 8x M10x25 Hex head



- 33. With the help of a mate or other lifting equipment, lift the slider up to the mount brackets. Align all the bolts so they fit through the corresponding holes in the brackets.
- 34. Once all the bolts are through into the brackets, put flange nuts on bolts to hold the slider up.

TOOLS REQUIRED

FASTENERS

8x M10 Flange Nut



- 35. Adjust the fore / aft position of sliders on mounts to achieve even appearance if required.
- 36. Torque all M10 flange nuts.
- 37. Repeat install steps 17-36 for the other step.

TOOLS REQUIRED

15mm socket/spanner

FASTENERS



38. Don't be stiff, put the supplied logo plates on the step as shown. It looks much better with it on.

TOOLS REQUIRED

FASTENERS



Congratulations!
Head for the tracks and enjoy your newly protected Wagon!