



www.Hsputelids.com
1300 441 498
Part No: VA12-1
Fitting Time: 15 mins



**Vehicle Model: VOLKSWAGEN
AMAROK NEW GENERATION
2023+**

HSP TAIL ASSIST

Fitting instructions

PARTS LIST

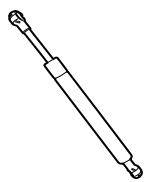
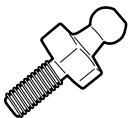
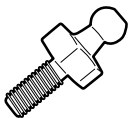
		
A DAMPER STRUT x1	B STUD BALL M10 x1	C STUD BALL M6 x1
KSD-SPEC-4	TA-25	TA-26

—GENERAL NOTES—

- Read through the fitting instructions prior to installation of accessory.
- Ensure all recyclable components and packaging are discarded and recycled following local recycling regulations.
- Safely store and protect any removed vehicle components.
- Trimming will be required.

—SAFETY NOTES—

- Check that all work practices comply with safety standards.
- Please wear appropriate clothing and use safety equipment.

—FITTING TIME—



25 mins

Open tailgate.

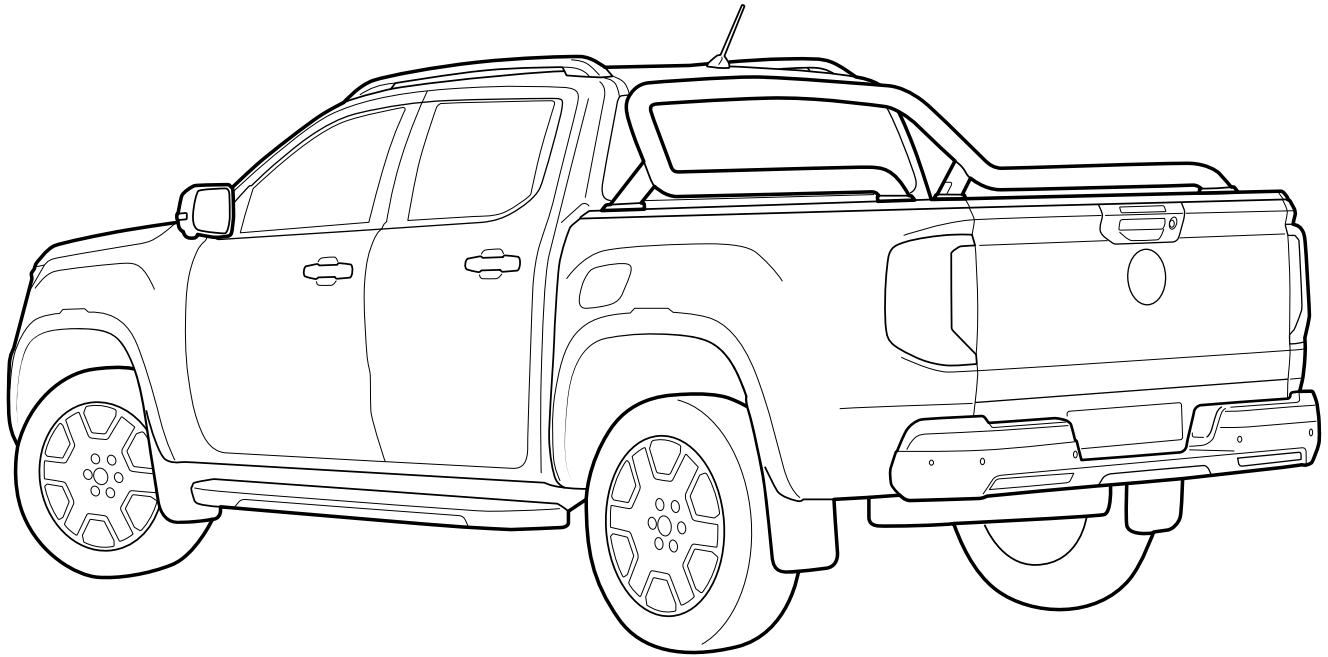

Remove tail light form vehicle.

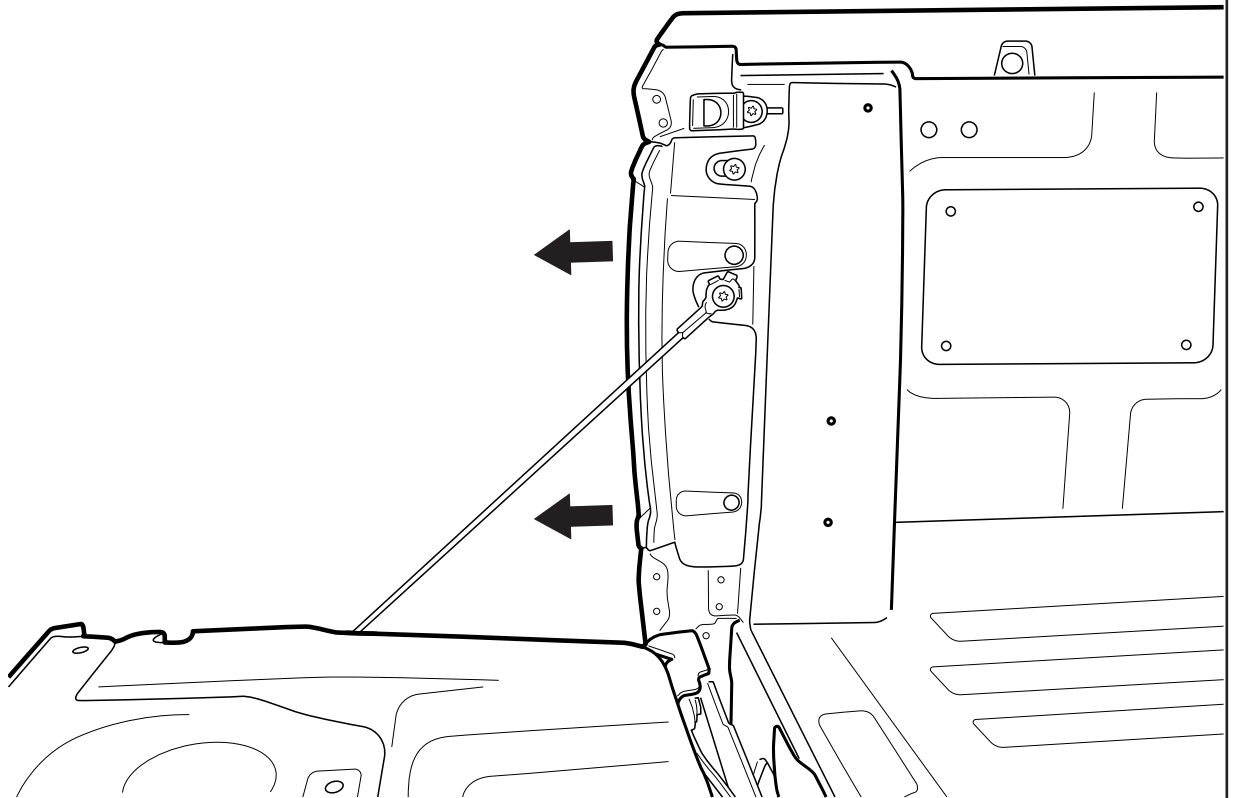

Measure 10mm inward and 10mm downward, then proceed to mark the specified position accordingly.

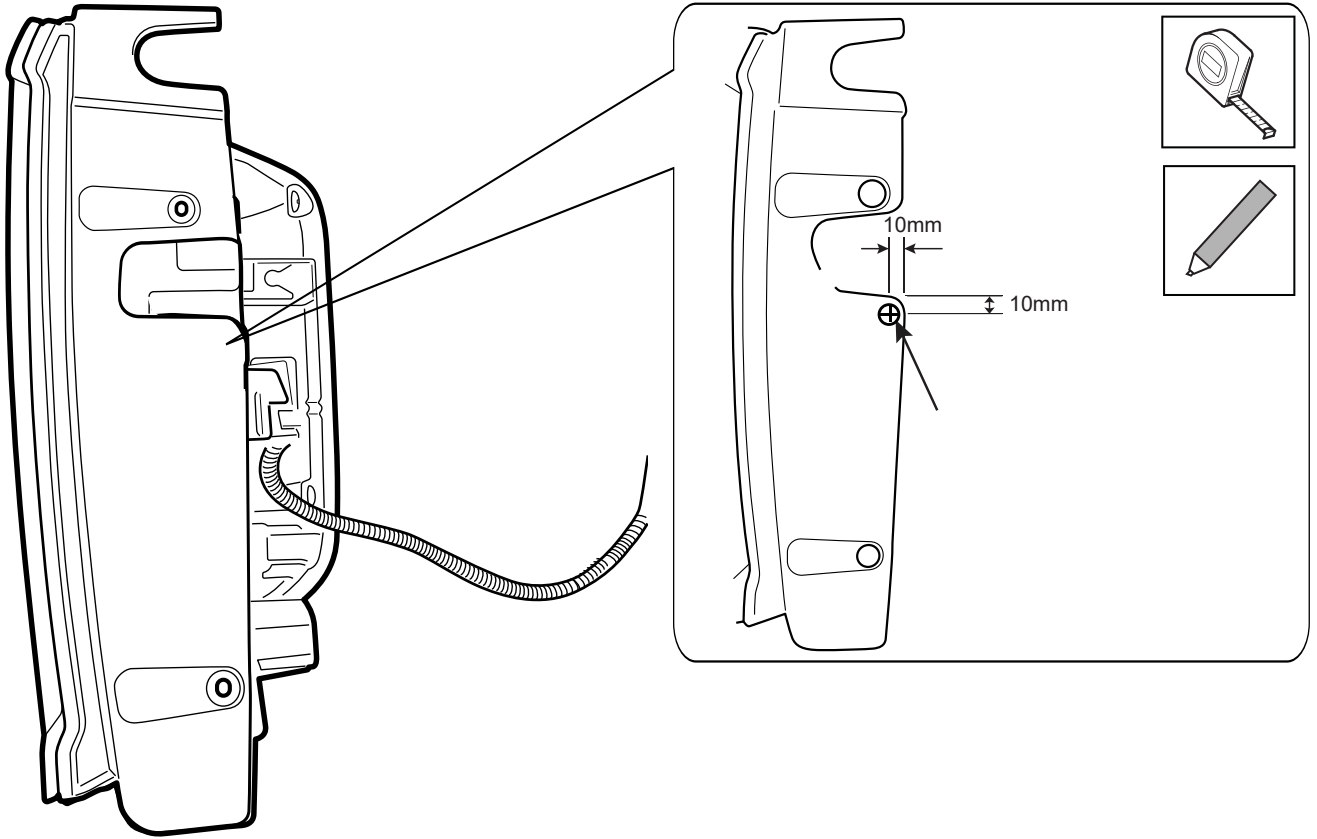

Exercise caution to avoid causing any harm to the inner cover of the tail light. At the designated spot, use a 50mm hole saw and trim out the plastic.

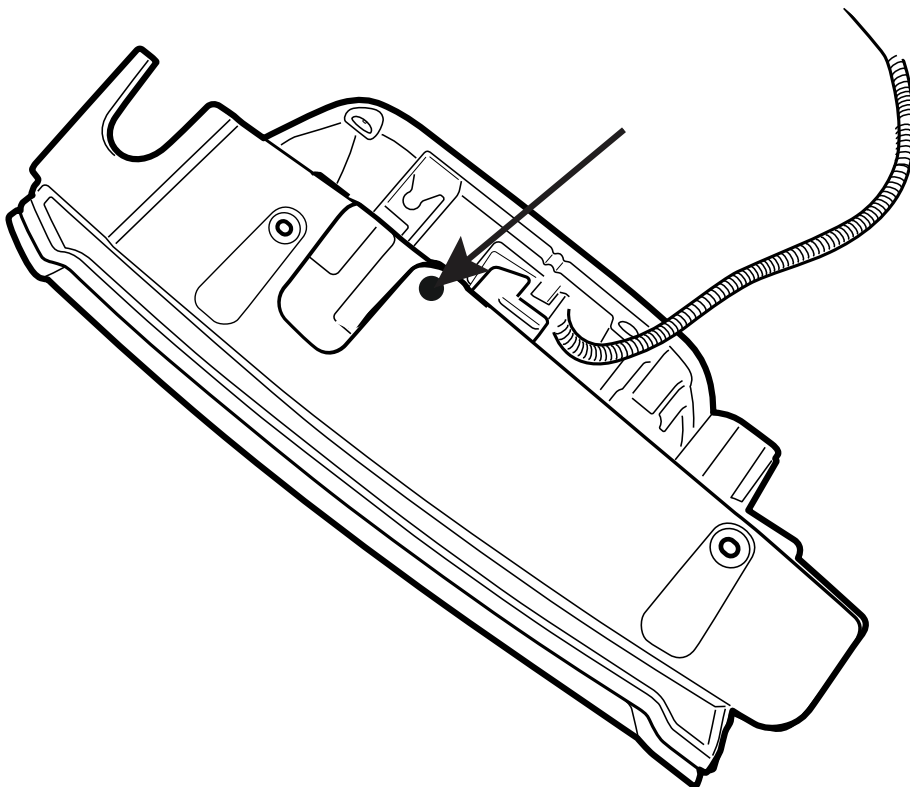
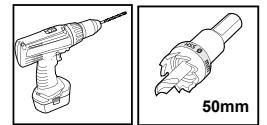

Discard trimmed section and refit the tail light to the vehicle.

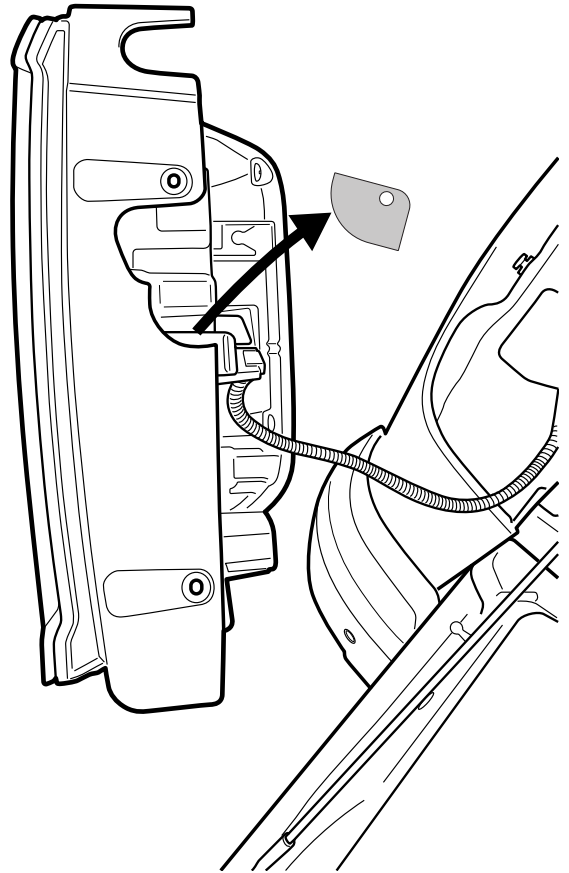

Using stud Ball M6, part number TA-26, fasten to indicated location.

NOTE: TA-26 Should be tighten to **2nm** torque, Do not use power tools for this step. Small amount of Loctite is recommended.

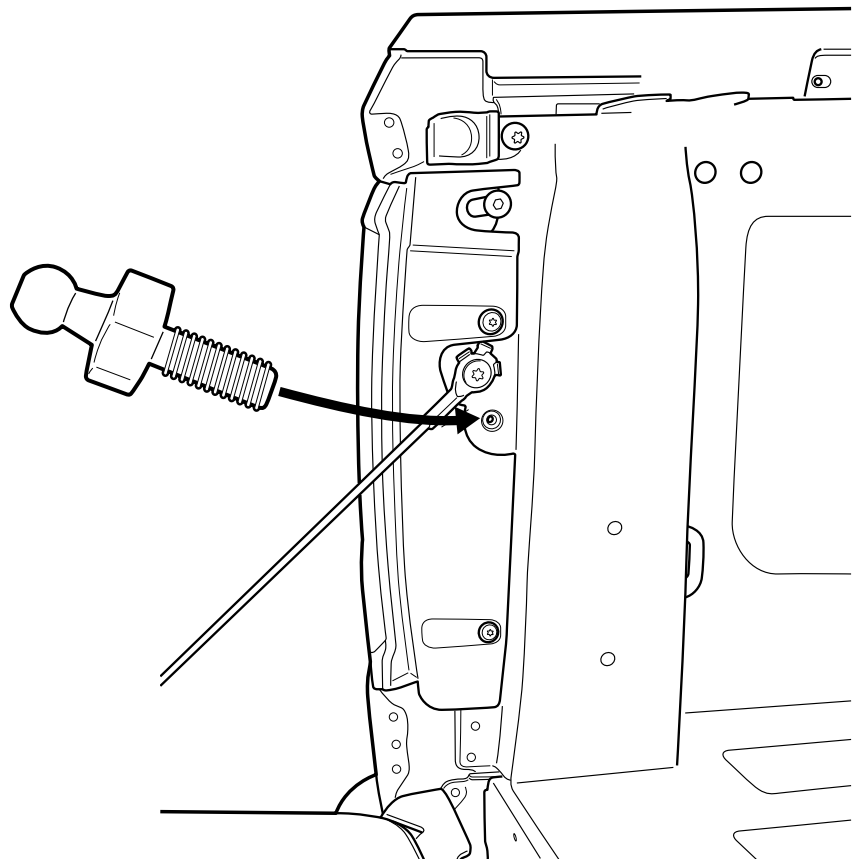

Remove indicated bolts, and discard. **NOTE: Take care not to lose factory alignment.**

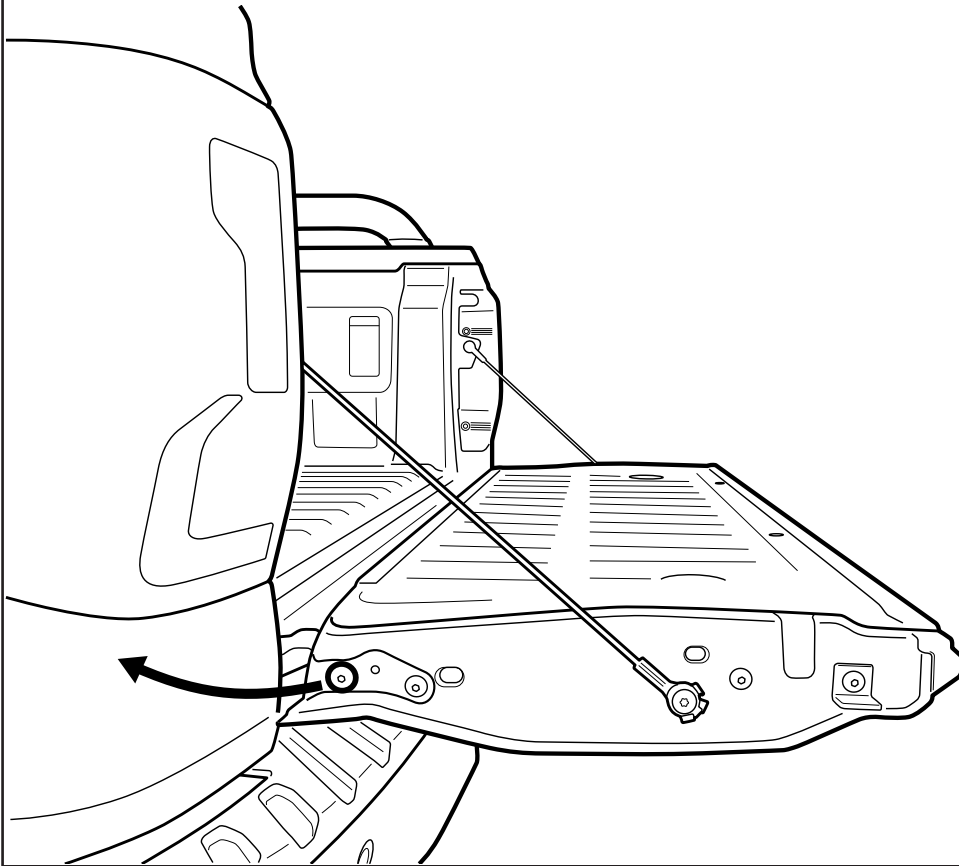

Using stud Ball M10, part number TA-25, fasten to indicated location.

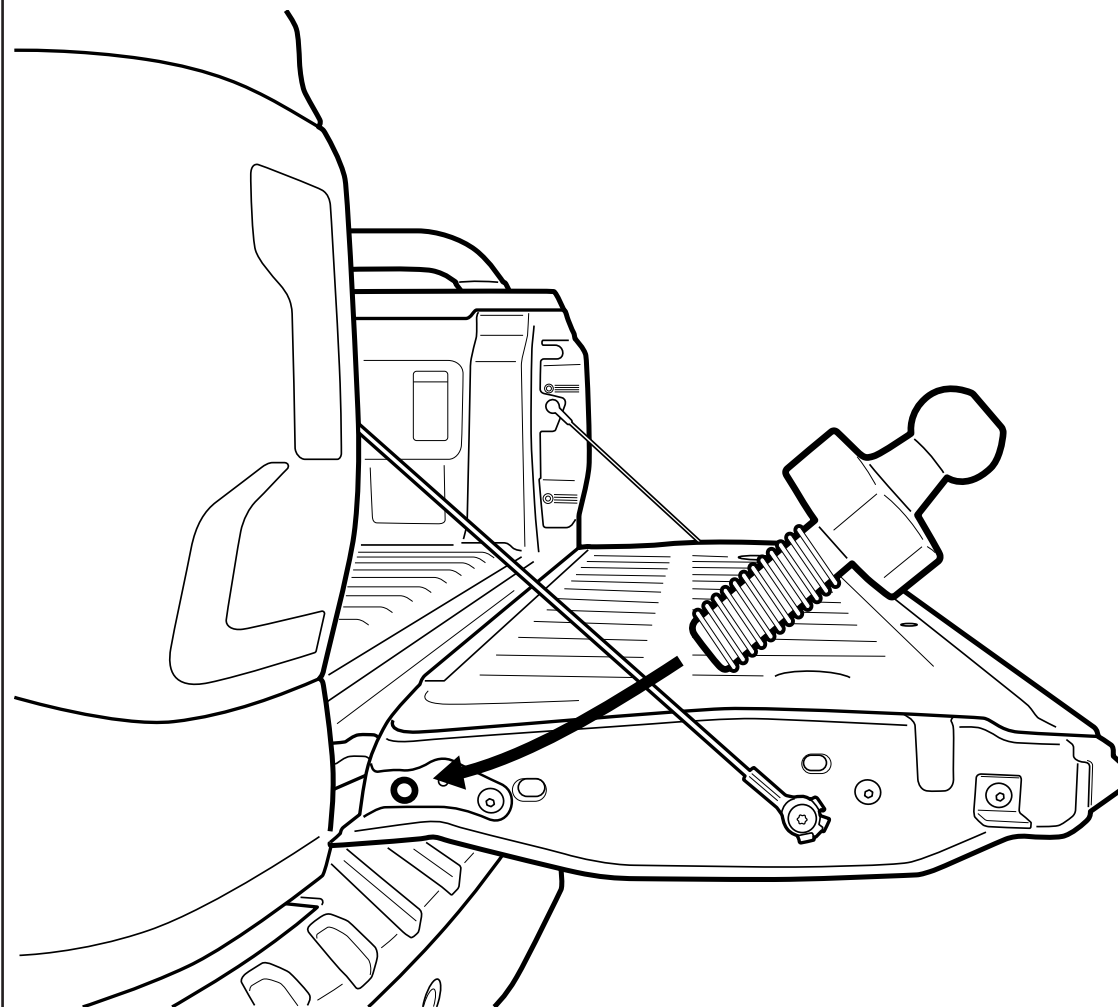

Align part number KSD-Spec-4 (cylinder end) to ball stud M6, push to click into position

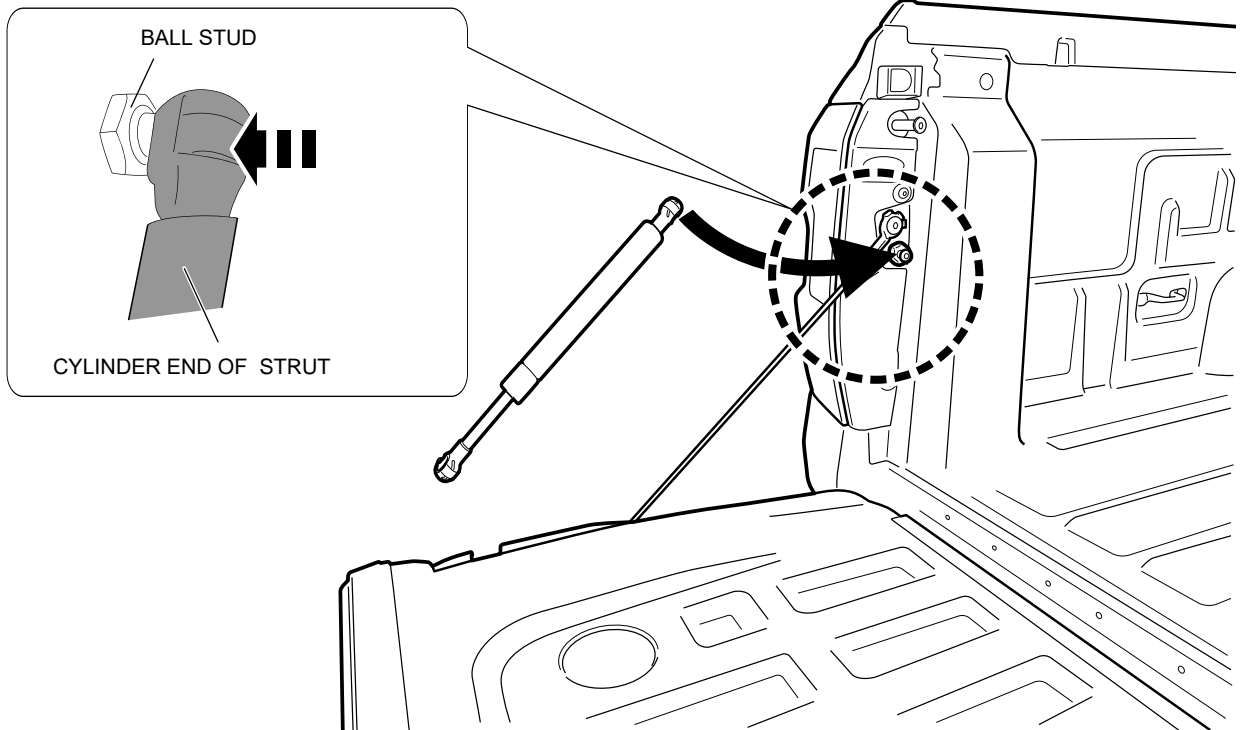

shaft to extend and click in to position.

