



Your 4x4 Accessory Adventure Partner.

FITTING INSTRUCTIONS

XEB-MAZ-02

Xcape Bullbar

Mazda BT-50 2021



All EFS Bull bars have been tested and are airbag & ADR compliant.
ANY MODIFICATIONS TO THE bull bar or its mounts WILL VOID THIS
COMPLIANCY And warranty

BEFORE INSTALLATION

- Please read the instructions completely before installing. This will allow for easy installation and help to avoid scratches or other potential damages to the vehicle.
- images are for reference only and may differ slightly from the actual product you are installing. Whilst images may differ, they share the same assembly instructions.







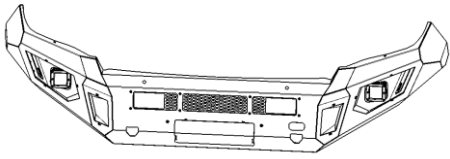
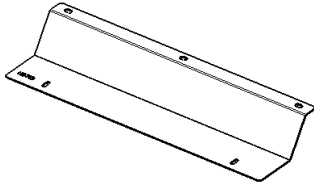
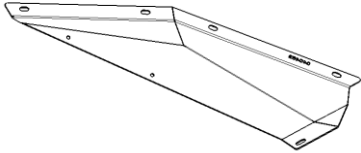
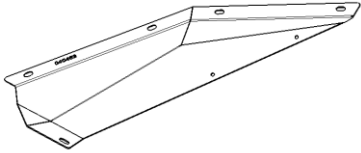
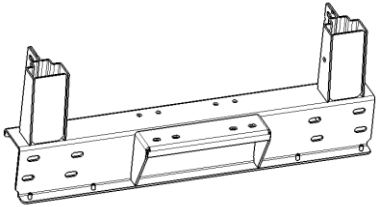
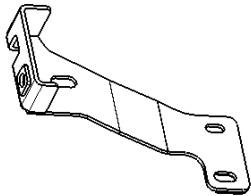
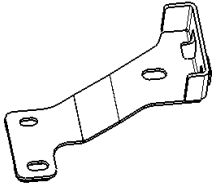
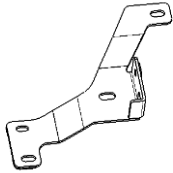
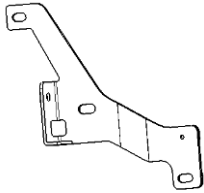
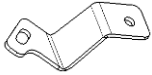
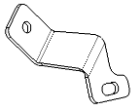
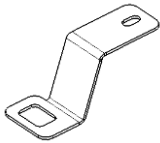

CARE & CLEANING

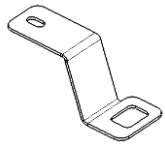
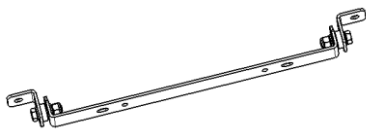
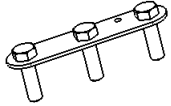



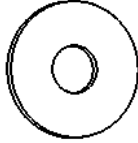
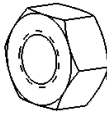
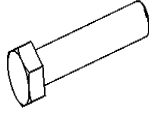
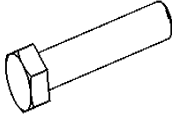

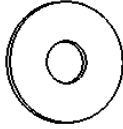

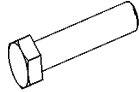

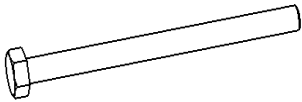
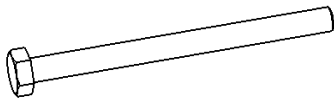

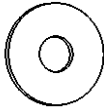
- Mild soap may be used to clean the bull bar.
- Check and retighten all the hardware regularly.

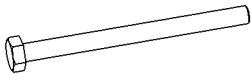
It is a condition of our warranty that Bullbar / Rearbars & Side rails / steps are installed by a suitably qualified installer. And is installed in accordance with accompanying installation instructions provided with item.

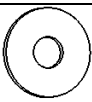
PARTS LIST

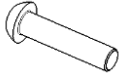
NO.	QTY	NAME	NO.	QTY	NAME
1	1	 Main bull bar Assembly	2	1	 Central Skid plate
3	1	 Skid plate (L)	4	1	 Skid plate(R)
5	1	 Winch Frame	6	1	 Outer Bracket -1 (L)
7	1	 Outer Bracket (R)	8	1	 Inner Bracket (L)
9	1	 Inner Bracket (R)	10	1	 Head Light Bracket (L)
11	1	 Head Light Bracket (R)	12	1	 Factory Bash Plate Holder (L)

13	1	 Factory Bash Plate Holder (R)	14	1	 License Bracket
15	2	 Bolt Plate	16	4	 spacer
17	6	 Wire ties	18	1	 LED Wiring Harness
Harware List :					
20	12	 Spring Washer D12	21	16	 Large Washer D12
22	10	 Hex Nut M12	23	2	 Hex bolt(Full Thread) M12_35
24	4	 Hex bolt(Full Thread) M12_45	25	8	 Spring Washer D10
26	16	 Large Washer D10	27	4	 Hex Nut M10
28	4	 Hex Nut M10	29	4	 Hex bolt(Full Thread) M12_35

		Hex Nut (Fine Thread) M10x1.25			Hex Bolt (Full Thread)(Fine Thread) M10x1.25_45
30	2	 Hex bolt(Full Thread) M10_90	31	2	 Hex bolt(Full Thread) M10_100
32	2	 Spring Washer D8	33	3	 Large Washer D8
34	1	 Hex Nut M8	35	1	 Hex bolt(Full Thread) M8_100
36	1	 Hex bolt(Full Thread) M8_85	37	2	 Spring Washer D6
38	2	 Large Washer D6	39	2	 Flange Hex Bolt M6_16
40	2	 Dome Head Bolt M6_25	41	8	 Hex Nut With Flange M6
41	23	 Bolt & Washer Assembly M6_20	43	1	 Wrench S=4

INSTALLATION FIG

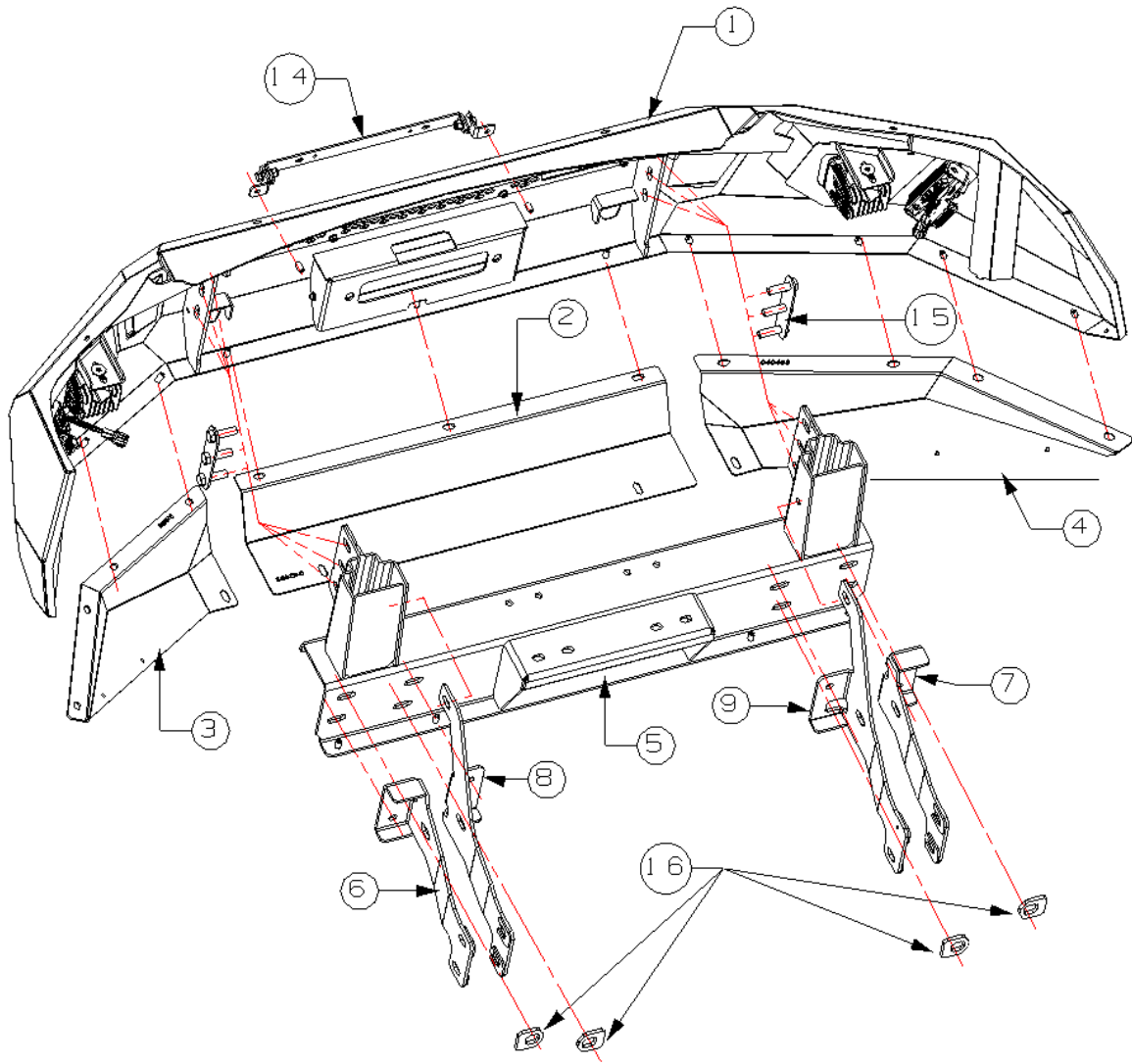

INSTALLATION INSTRUCTIONS

Step 1: Verify that all parts are present according to the manual. Remove the factory front bumper.

- Remove the air intake clips and move air intake to the side.



- Remove the screws and clips from the front nose cone and remove



- Remove and retain the clips holding the top cover on
- Remove the screw from the Mazda badge on the grill (From the front)



- Remove the clips from behind the grill
- Remove the 4 clips and screw from inside the wheel arch
- Remove the nut and clips from underside of the front bumper

Step 2: Remove factory front bumper, intrusion beam and bash plate. find the installation position shown in the figure, which on the side of the headlights, then install headlight brackets (L/R) supported with M6 hardware.

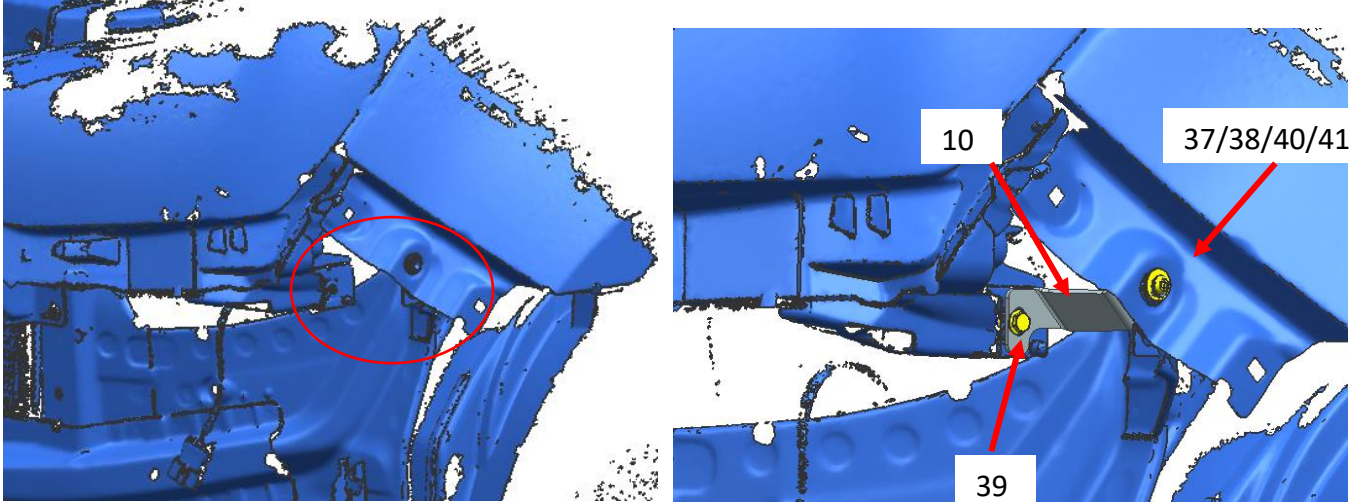

Step 3: Connect brackets with the beam by following figure. Left and right side are the same way to install.

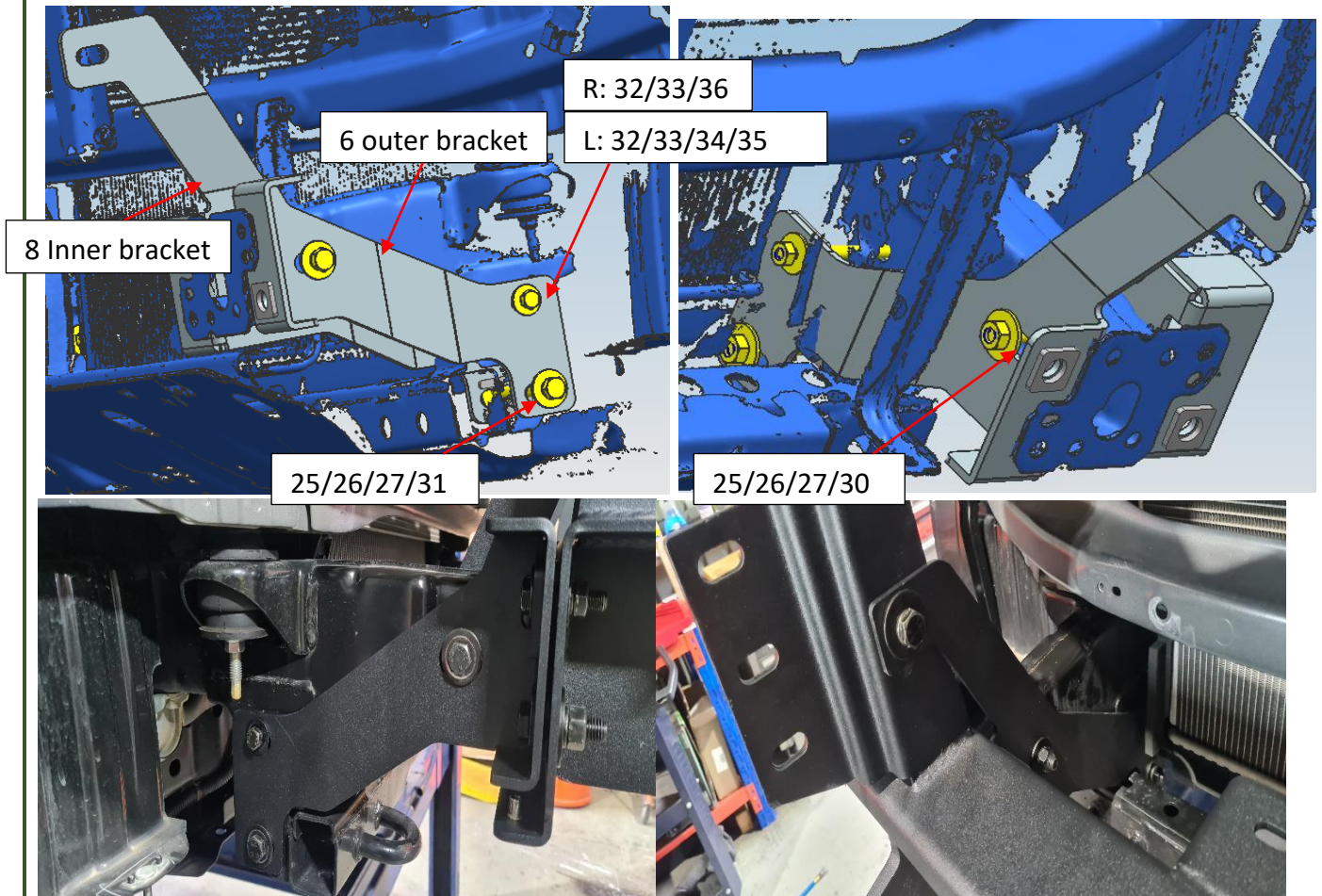

Step 4: Connect winch frame to the chassis end plate and above bracket shown as below.

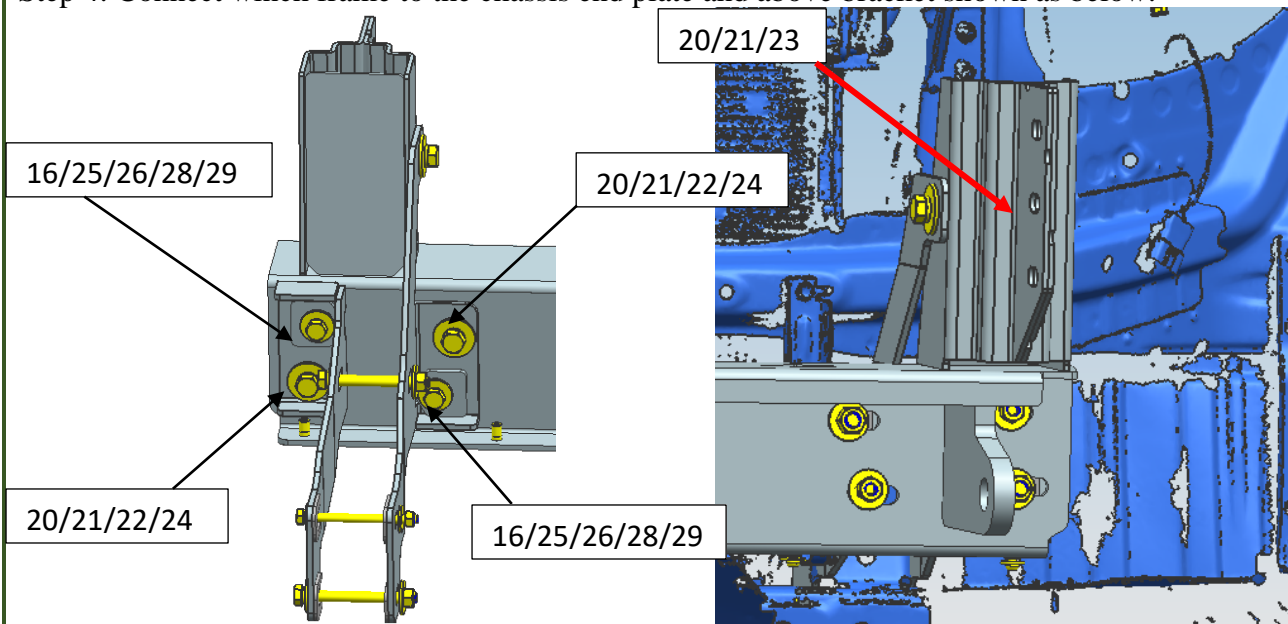

If you are installing a winch, please proceed with this before going further.

Step 5: You will need to cut the grill as pictured below and fit back to vehicle before installing main bulbar assembly.

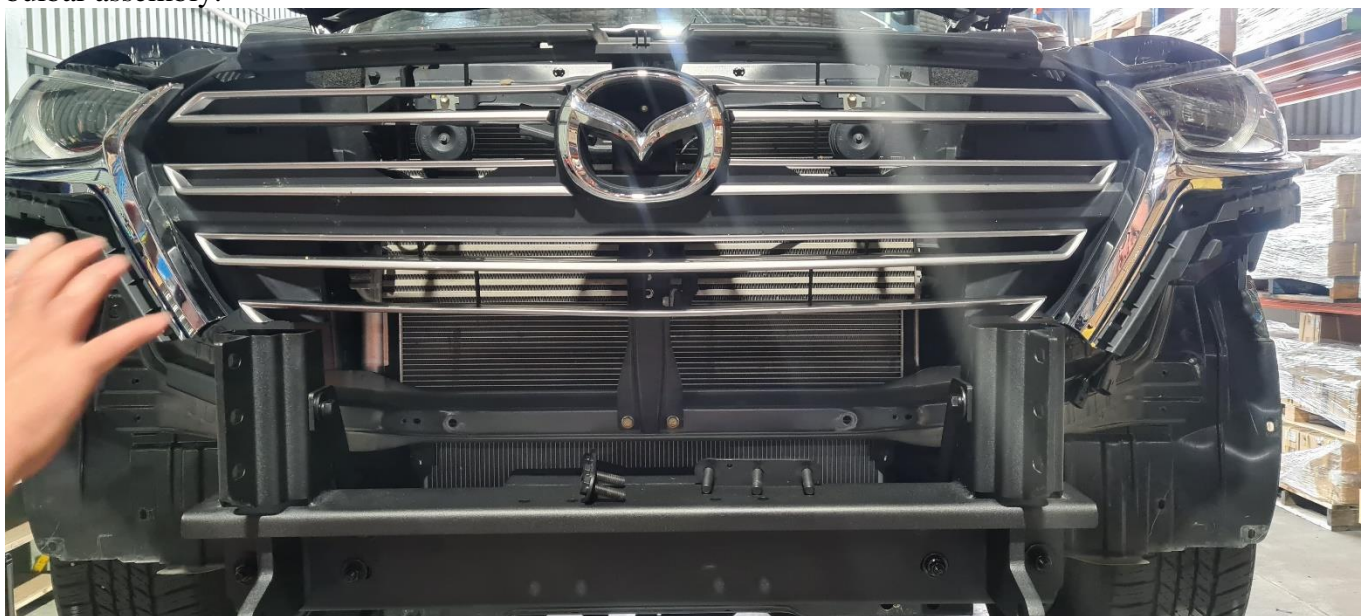

Step 6: Connect the bull bar on the winch frame shown as below:

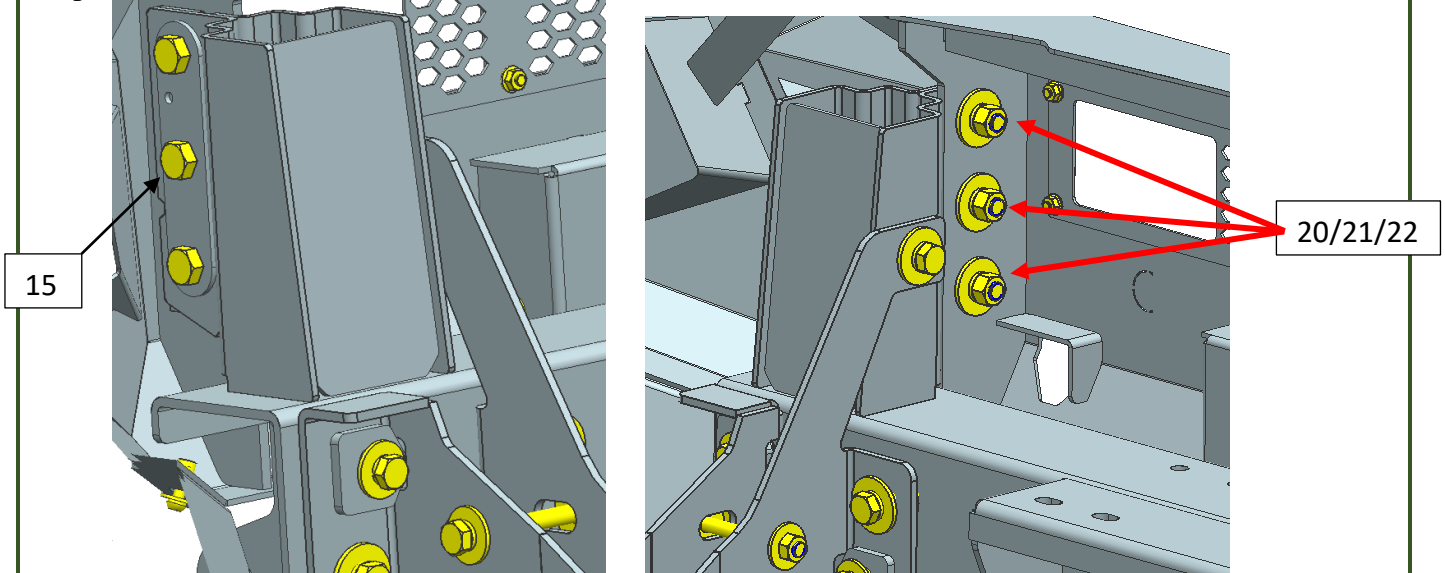

Step 7: Re-install the factory bash plate/stone tray with the supplied holder and original fasteners as shown in following pictures.

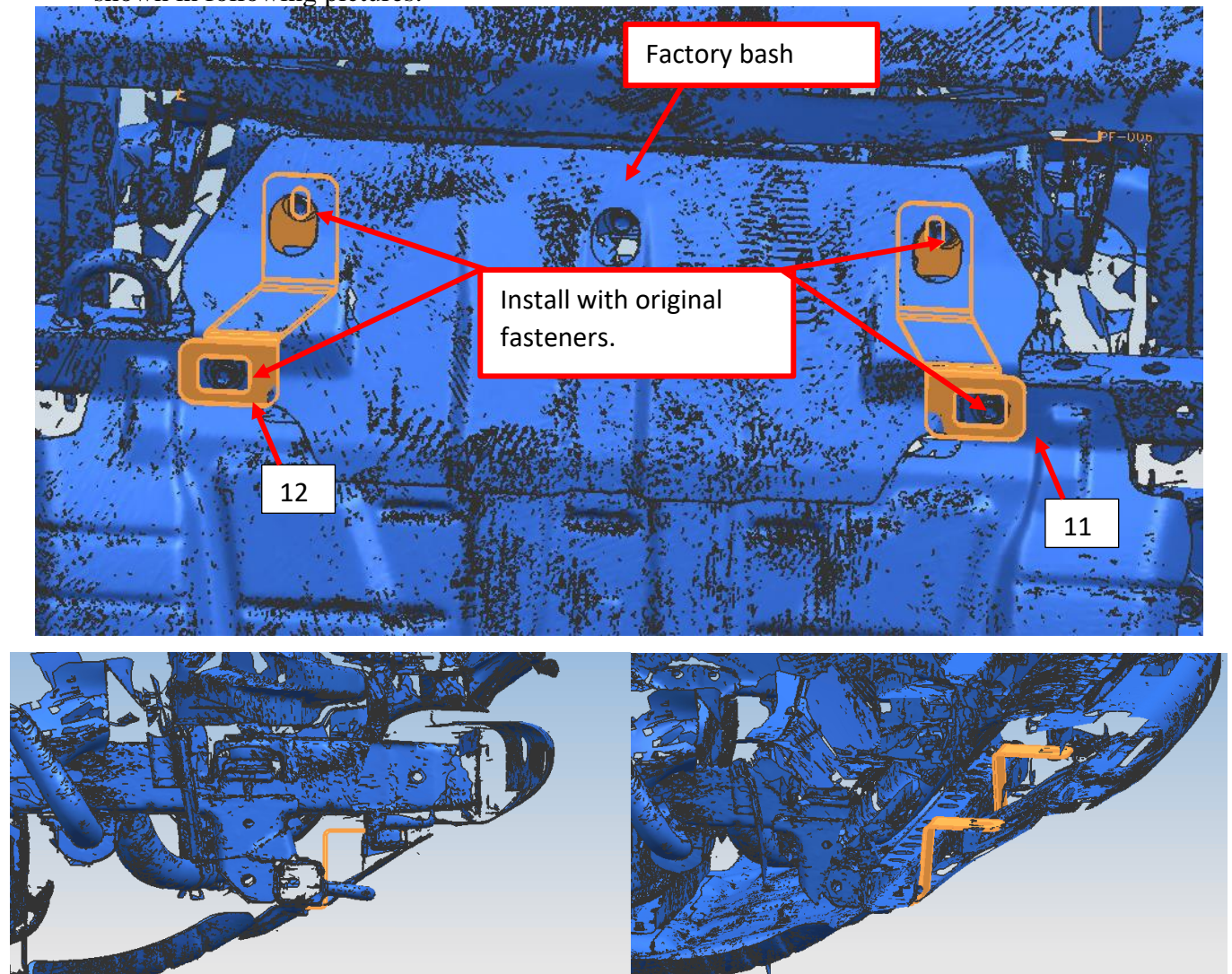

Step 8: Install skid plates to bulbar as pictured.

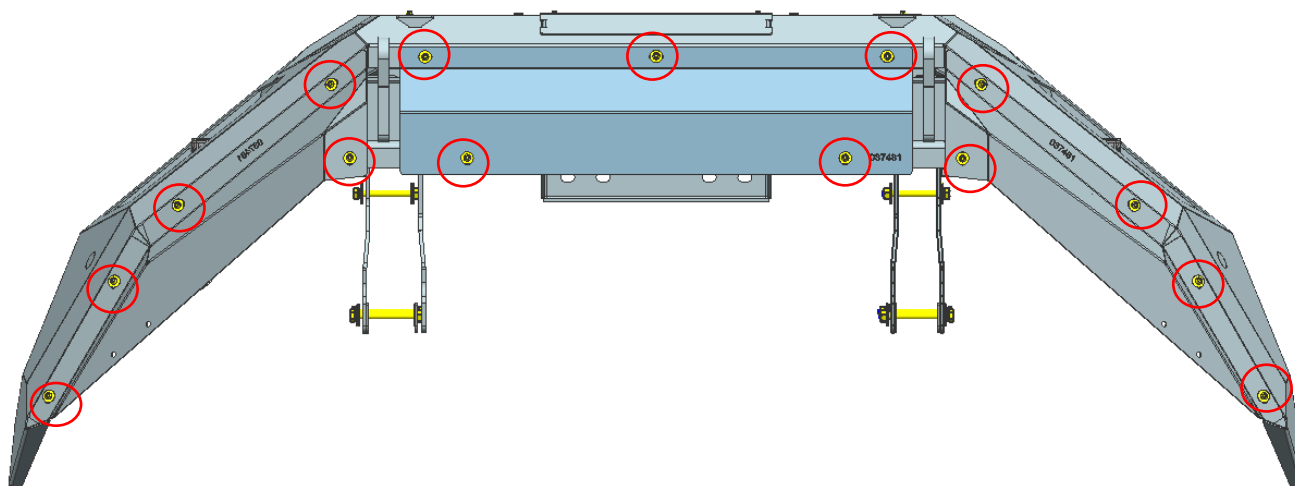

PS. Fix the factory mud plate by hardware 41/42 on the following position shown as below:

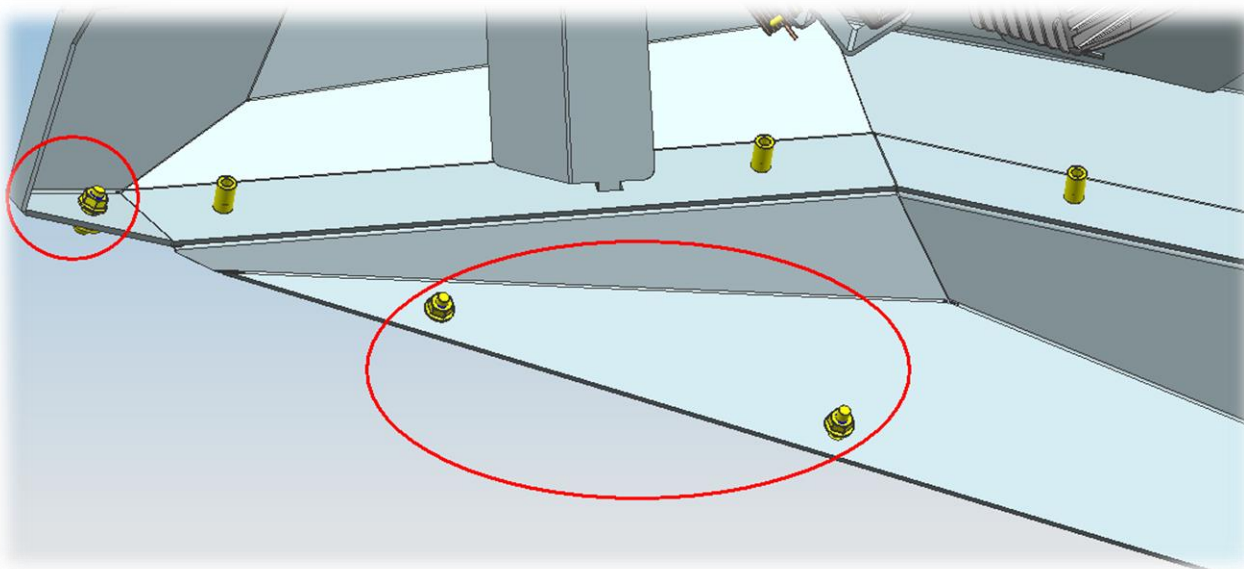

Step 8 Install license bracket shown as below.

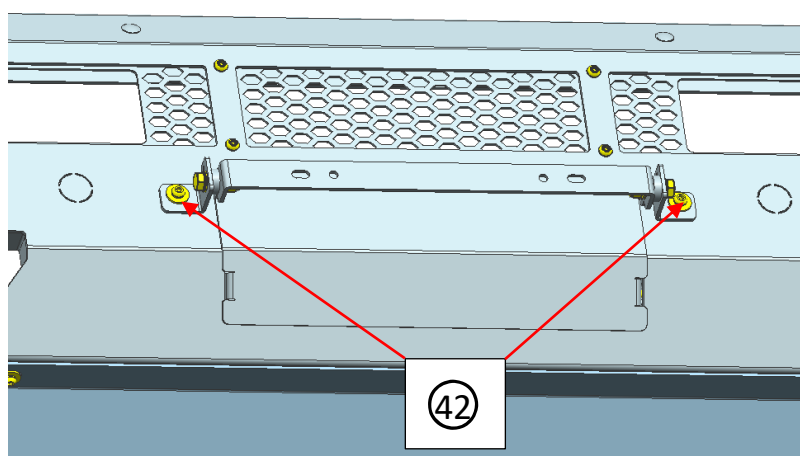

Step 9: Test and make sure that the guard is steadily fixed, fully tighten all hardware.

Step 10: Installation is finished, pick up all tools.

NOTE

Any damages or loss caused by the improper installation and use of EFS Accessories will not be covered by warranty.

Please ensure you leave sufficient spacing between bullbar and guards

